

## ПРЕДПРИЯТИЕ МАКСАЭРО

- Производство воздуховодов и систем вентиляции
- Клапаны противопожарные
- Клапаны дымоудаления
- Вентиляторы общепром, дымоудаления, крышные

220056, г. Минск, ул. Стариновская, 15

Тел./факс: +375 17 244-67-44, 258-67-51, 347-73-56, 252-54-27

Velcom: +375 29 603-88-99

E-mail: [olegaero@yandex.by](mailto:olegaero@yandex.by)

[www.maxaero.by](http://www.maxaero.by)



# Поворотный привод Siemens GDB111.9E/KN



ACVATIX™

## Rotary actuator for ball valves KNX / PL-Link

G..B111.9E/KN

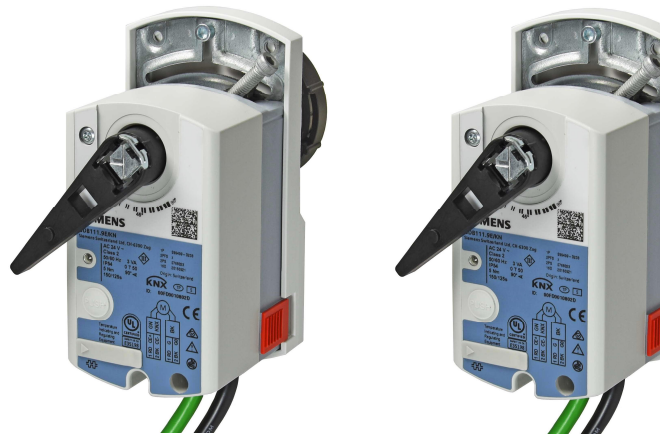

### Rotary actuator 5 / 10 Nm with KNX communication for 6-port control ball valves and ball valves

- GDB111.9E/KN with 5 Nm nominal torque
- GLB111.9E/KN with 10 Nm nominal torque
- Operating voltage AC 24 V
- Supports KNX S-Mode and PL-Link
- For use with VWG41.. 6-port control ball valves and with 2-port and 3-port ball valves up to DN 25 / DN 50

## Functions

Function	Description
<b>Communication</b>	<ul style="list-style-type: none"> <li>- KNX-TP, galvanically separated</li> <li>- Max. 256 nodes per line (with repeaters)</li> <li>- Busload 5 mA</li> </ul>
<b>Functions</b>	<ul style="list-style-type: none"> <li>- Setpoint and actual value for actuator position 0..100%</li> <li>- Operating mode "heating / cooling control" for 6-port control ball valve or operating mode "position control" for 2-/3-port control ball valves</li> <li>- Override control with binary communication objects</li> <li>- Setpoint monitoring and backup mode</li> </ul>

## Type summary

Product no.	Ordering no.	Operating voltage	Control signal	Power consumption	Running time	Manual override	Position feedback
<b>GDB111.9E/KN</b>	S55499-D203	AC 24 V	KNX-TP	1 VA / 0.5 W 3 VA / 2.5 W <sup>1)</sup>	150 s	Yes	Yes
<b>GLB111.9E/KN</b>	S55499-D207						

<sup>1)</sup> Actuator rotates

### Ordering information (example)

Product no.	Ordering no.	Description	Volume
GDB111.9E/KN	S55499-D203	Rotary actuator KNX for 6-port ball valve or control ball valves	1

## Equipment combinations

6-port control ball valves PN16				GDB..9E..	
Medium: 5...90 °C	G..B	k <sub>vs</sub> [m <sup>3</sup> /h]	DN	Δp <sub>max</sub> [kPa]	
VWG41.10..	G ½ B	0.25 .. 1.9	10	200	
VWG41.20..	G 1 B	0.25 .. 4.25	20	200	

2- and 3-port control ball valves PN40						GDB..9E		GLB..9E	
internally threaded	Rp	externally threaded	G..B	$k_{vs}$ [m <sup>3</sup> /h]	DN	$\Delta p_{max}$	$\Delta p_s$	$\Delta p_{max}$	$\Delta p_s$
2-port control ball valves									
–	–	<b>VAG61.15..</b>	G 1 B	1...6.3	15	350	1400	-	-
<b>VAI61.15..</b>	Rp ½"	–	–	1...10	15				
<b>VAI61.20..</b>	Rp ¾"	<b>VAG61.20..</b>	G 1 ¼ B	4...10	20				
<b>VAI61.25..</b>	Rp 1"	<b>VAG61.25..</b>	G 1 ½ B	6.3...16	25				
<b>VAI61.32..</b>	Rp 1¼"	<b>VAG61.32..</b>	G 2 B	10...25	32	-	-	350	1000
<b>VAI61.40..</b>	Rp 1½"	<b>VAG61.40..</b>	G 2 ¼ B	16...40	40				800
<b>VAI61.50..</b>	Rp 2"	<b>VAG61.50..</b>	G 2 ¾ B	25...63	50				600
3-port control ball valves									
<b>VBI61.15..</b>	Rp ½"	<b>VBG61.15..</b>	G 1 B	1.6...6.3	15	350	-	-	-
<b>VBI61.20..</b>	Rp ¾"	<b>VBG61.20..</b>	G 1 ¼ B	4...6.3	20				
<b>VBI61.25-10</b>	Rp 1"	<b>VBG61.25-10</b>	G 1 ½ B	10	25				
<b>VBI61.32-16</b>	Rp 1¼"	<b>VBG61.32-16</b>	G 2 B	16	32	-	-	350	-
<b>VBI61.40-25</b>	Rp 1½"	<b>VBG61.40-25</b>	G 2 ¼ B	25	40				
–	–	<b>VBG61.50-40</b>	G 2 ¾ B	40	50				
<b>VBI61.50..</b>	Rp 2"	–	–	40...63	50				

Cf. section "product documentation" for datasheet numbers

Open/close 2-port and changeover ball valves 3-port PN 40						GDB..9E		GLB..9E	
internally threaded	Rp	externally threaded	G..B	$k_{vs}$ [m <sup>3</sup> /h]	DN	$\Delta p_{max}$	$\Delta p_s$	$\Delta p_{max}$	$\Delta p_s$
Open/close 2-port ball valves									
–	–	<b>VAI60.15-9</b>	G 1 B	9	15	350	1400	-	-
<b>VAI60.15-15</b>	Rp ½"	–	–	15	15				
–	–	<b>VAG60.20-17</b>	G 1 ¼ B	17	20				
<b>VAI60.20-22</b>	Rp 1"	–	–	22	20				
<b>VAI60.25-22</b>	Rp 1"	<b>VAG60.25-22</b>	G 1 ½ B	22	25	-	-	350	1000
<b>VAI60.32-35</b>	Rp 1¼"	<b>VAG60.32-35</b>	G 2 B	35	32				800
<b>VAI60.40-68</b>	Rp 1½"	<b>VAG60.40-68</b>	G 2 ¼ B	68	40				600
<b>VAI60.50-96</b>	Rp 2"	<b>VAG60.50-96</b>	G 2 ¾ B	96	50				
Changeover ball valves 3-port									
<b>VBI60.15-5L</b>	Rp ½"	–	–	5	15	350	-	-	-
<b>VBI60.20-9L</b>	Rp 1"	–	–	9	20				
<b>VBI60.25-9L</b>	Rp 1"	–	–	9	25				
<b>VBI60.32-13L</b>	Rp 1¼"	–	–	13	32	-	-	350	-
<b>VBI60.40-25L</b>	Rp 1½"	–	–	25	40				
<b>VBI60.50-37L</b>	Rp 2"	–	–	37	50				
Changeover ball valves 3-port									
–	–	<b>VBG60.15-8T</b>	G 1 B	8	15	350	-	-	-
<b>VBI60.15-12T</b>	Rp ½"	–	–	12	15				
–	–	<b>VBG60.20-13T</b>	G 1 ¼ B	13	20				
<b>VBI60.20-16T</b>	Rp 1"	–	–	16	20				
–	–	<b>VBG60.25-13T</b>	G 1 ½ B	13	25				
<b>VBI60.25-16T</b>	Rp 1"	–	–	16	25				
<b>VBI60.32-25T</b>	Rp 1¼"	<b>VBG60.32-25T</b>	G 2 B	25	32	-	-	350	-
<b>VBI60.40-49T</b>	Rp 1½"	<b>VBG60.40-49T</b>	G 2 ¼ B	49	40				
<b>VBI60.50-73T</b>	Rp 2"	<b>VBG60.50-73T</b>	G 2 ¾ B	73	50				
Changeover ball valves 3-port									

Cf. section "product documentation" for datasheet numbers

Controllers and room units	Product no.	Ordering no.	Documentation
Room thermostat KNX	RDG160KN	S55770-T297	A6V10629627 (N3191)
Flush-mount room sensor KNX	AQR2532NNW with AQR2570NF or AQR2576NF	S55720-S136 S55720-S203 S55720-S207	A6V10389050 (N1411)
Room control unit	UP227/11	5WG1227-2AB11	A6V10387579

## Software versions

G..B111.9E/KN series B are designed for using ETS device profile v2.x. ETS device profile v1.x is supported for backward compatibility reasons.

Series information	Series A	Series B
Production period	12/2015 – 01/2017	01/2017
ETS device profile v1.x	supported	supported
ETS device profile v2.x	not supported	supported

**Note:** The Software-Tools ACS931 / 941 and the handheld tool AST20 are not supported by the GDB111.9E/KN and GLB111.9E/KN.

## Product documentation

Title	Topic	Document ID
Communication via the KNX bus	Communication via the KNX bus	A6V10075840 (P3127)
Mounting instruction	Mounting instructions rotary actuator	A6V10523083 (M4657) or A6V10636144
Datasheet 6-port control ball valve	Technical information on 6-port control ball valves VWG41..	A6V10564480
Datasheet 2-port and 3-port control ball valves, PN 40, with internally threaded connection	Technical information on 2-port and 3-port control ball valves VAI61... and VBI61..	N4211
Datasheet 2-port and 3-port control ball valves, PN 40, with externally threaded connection	Technical information on 2-port and 3-port control ball valves VAG61... and VBG61..	N4212
Datasheet 2-port shutoff valves and 3-port changeover ball valves, PN 40, with internally threaded connection	Technical information on 2-port shutoff and 3-port changeover ball valves VAI60... and VBI60..	N4213
Datasheet 2-port shutoff valves and 3-port changeover ball valves, PN 40, with externally threaded connection	Technical information on 2-port shutoff and 3-port changeover ball valves VAG60... and VBG60..	N4114

### Push-button operation

Activity	Push-button operation	Confirmation
Enter / leave addressing mode	Press button <1 s	LED turns red or gets off
Reset to factory settings	Press button >20 s	LED flashes orange until device restarts
PL-Link connection test <sup>1)</sup>	Press key >2 s and <20 s	LED flashes 1x orange

<sup>1)</sup> Function or part of the function available in PL-Link operation only

### LED colors and patterns

Color	Pattern	Description	
Off	---	Fault free operation or device not powered	
Green	steady	Connection test successful <sup>1)</sup>	
Orange	flashing	0.1 s on / 0.1 s off	Factory reset in progress
		0.25 s on / 1.75 s off	When a connection test was triggered: wait <sup>1)</sup>
Red	steady	Device is in programming/addressing mode	
	flashing	0.5 s on / 2 s off	Internal error: Power reset necessary
		1 s on / 1 s off	When a connection test was triggered: Connection test failed <sup>1)</sup>

<sup>1)</sup> Function or part of the function available in PL-Link operation only

### Addressing and bus test with push button

The rotary actuators can be set into addressing/programming mode by push-button:

- Press push button (<1 s)
- KNX bus wiring OK → LED turns red until addressing/programming is finished
- KNX bus wiring not OK → LED stays dark

### Reset with push button

The rotary actuators can be reset by push-button:

- Press push button >20 s
- LED flashes orange
- Device restarts

All parameters are reset to the default values.

## Commissioning and parameterization

The following operating modes are available:

- Heating / cooling control: The actuator uses two separate setpoints for heating and cooling each with a range 0...100%.
- Position control: The actuator is controlled with a 0...100% position setpoint.

### Operating mode “Heating / cooling control”

When using “heating / cooling control” the parameters as listed below are available. Parameter sets for 6-port control ball valves DN 10 and DN 20 can be selected. Details on the characteristic curves of these two valves can be found in the datasheet A6V10564480.

Note that the valve angle [°] moves counter-clockwise, whereas the actuator position [%] moves clockwise. Therefore valve angle 15° is achieved by an actuator position of 84% etc.

One of the two setpoints (heating or cooling) needs to be “0%” in order for the actuator to be able to move. Are both setpoints not equal to “0%”, the actuator doesn’t move until the setpoint conflict is resolved.

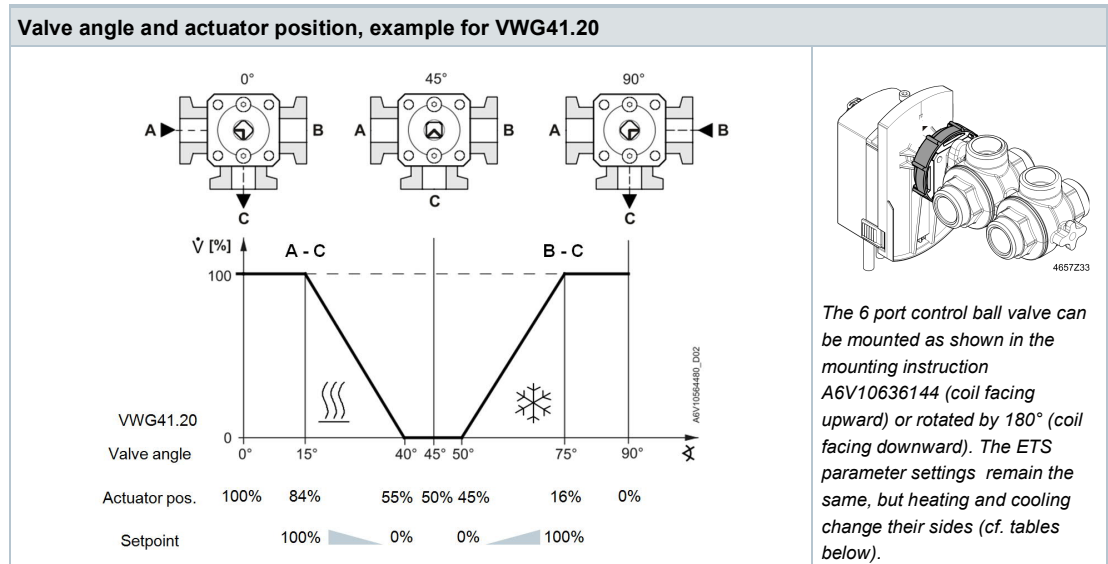

Parameters for standard piping of heating / cooling:

Parameter	VWG41.10		VWG41.20	
	Valve angle	Actuator position	Valve angle	Actuator position
Max. position heating	15°	84%	15°	84%
Min. position heating	30°	67%	40°	55%
Closed position	45°	50%	45°	50%
Min. position cooling	60°	33%	50°	45%
Max. position cooling	75°	16%	75°	16%

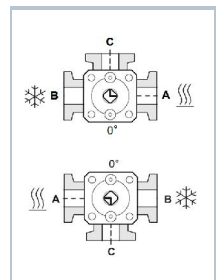

By parameter inversion, heating and cooling are swapped:

Parameter	VWG41.10		VWG41.20	
	Valve angle	Actuator position	Valve angle	Actuator position
Max. position heating	15°	16%	15°	16%
Min. position heating	30°	33%	40°	45%
Closed position	45°	50%	45°	50%
Min. position cooling	60°	67%	50°	55%
Max. position cooling	75°	84%	75°	84%

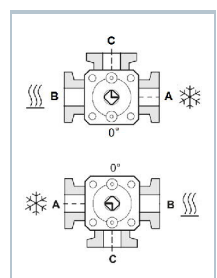

## Operating mode “Position control”

Parameters available in “position control”:

Parameter	Range	Description	Factory setting
Opening direction	CW (R) / CCW (L)	Opening direction of the actuator	CW (R)
Max. position	0...100%	Setting for the upper position limit	100%
Min. position	0...100%	Setting for the lower position limit	0%

## Parameterization of the KNX bus integration

The following parameters are usually checked and set by the systems integrator to achieve the right level of bus traffic generated by the actuator or to define the behavior in case of communication interruption. Parameters in the group “advanced” can be left unchanged unless a special configuration is required.

Parameter group “Standard”:

Parameter	Range	Description	Factory setting
Backup timeout	0...60 min 0 min = disabled	Time interval to detect communication interruption. If disabled, the actuator controls to the last received setpoint until a new setpoint is received.	30 min.
Backup mode	Backup position Keep last position	Actuator behavior when the communication timeout has been exceeded (no setpoint received within the defined time interval). <ul style="list-style-type: none"><li>• Backup position: Actuator drives to defined position</li><li>• Keep last position: Actuator keeps position</li></ul>	Backup position
Backup value	0...100%	Position the actuator drives to in case of communication interruption	50%

Parameter group “Advanced”:

Parameter	Range	Description	Factory setting
Hysteresis (COV) actuator position <sup>1)</sup>	1...20%	Threshold for the actuator position. COV below this value are not sent over the bus	1%
Min. repetition time actuator position	10...900 s	Minimum waiting time until a COV above the hysteresis threshold is sent over the bus	10 s
Override position 1 <sup>2)</sup>	0...100%	Position to which the actuator drives if the associated group object is triggered (override priority)	50 %
Override position 2 <sup>2)</sup>	0...100%	Position to which the actuator drives if the associated group object is triggered (override priority)	50 %

<sup>1)</sup> COV = Change of value

<sup>2)</sup> Override position 1 has priority over Override position 2

## Notes

### Safety

#### Caution

##### National safety regulations

Failure to comply with national safety regulations may result in personal injury and property damage.

- Observe national provisions and comply with the appropriate safety regulations.

### Mounting

#### Mounting positions

##### IP54 in the following mounting positions

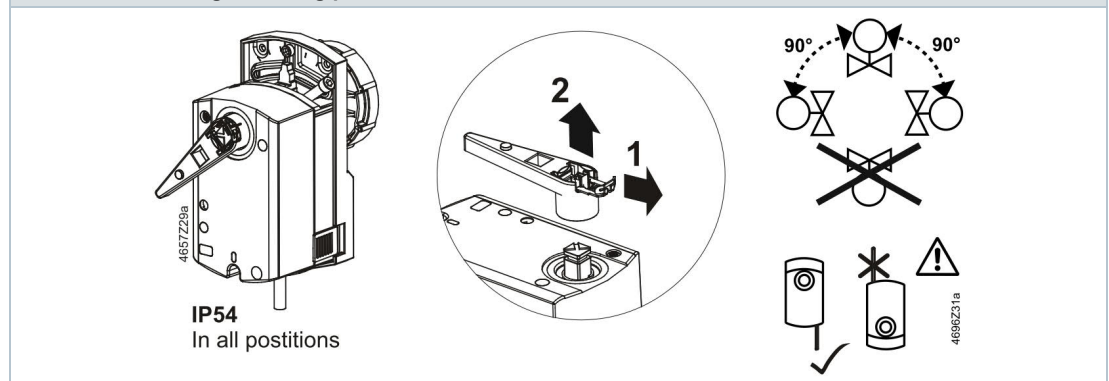

### Maintenance

The rotary actuators are maintenance-free.

Disconnect the electrical connections from the terminals if you want to work at the device.

### Disposal



The device is considered electrical and electronic equipment for disposal in terms of the applicable European Directive and may not be disposed of as domestic garbage.

- Dispose of the device through channels provided for this purpose.
- Comply with all local and currently applicable laws and regulations.

## Warranty

Technical data on specific applications are valid only together with Siemens products listed under "Equipment combinations". Siemens rejects any and all warranties in the event that third-party products are used.

#### Note

**When using the actuators in connection with components of other manufacturers, correct functioning must be ensured by the user, and Siemens will assume no responsibility.**

## KNX Group Objects

Nr.	Name in ETS	Object function	Flags					Data point type KNX				Range
			C	R	W	T	U	ID	DPT_Name	Format	Unit	
1	Fault information	Transmit	1	1	0	1	0	219.001	_AlarmInfo	6 Byte	---	[0...255 ] = Log Nr. [0...2] = Alarm priority [0...14] = Application area [0...4] = Error class [0...7] = Attributes [0...7] = Alarm status
2	Fault state	Transmit	1	1	0	1	0	1.005	_Alarm	1 bit	---	0 = No alarm 1 = Alarm
3	Fault transmission	Receive	1	0	1	0	1	1.003	_Enable	1 bit	---	0 = Disable 1 = Enable
4	Setpoint position / Setpoint pos. heating <sup>1)</sup>	Receive	1	1	1	0	1	5.001	_Scaling	1 Byte	%	0..100%
5	Actual position / Actual position heating <sup>1)</sup>	Transmit	1	1	0	1	0	5.001	_Scaling	1 Byte	%	0..100%
6	Setpoint pos. cooling <sup>1)</sup>	Receive	1	1	1	0	1	5.001	_Scaling	1 Byte	%	0..100%
7	Actual position cooling <sup>1)</sup>	Transmit	1	1	0	1	0	5.001	_Scaling	1 Byte	%	0..100%
8	Fault	Transmit	1	1	0	1	0	1.005	_Alarm	1 bit	---	0 = No alarm 1 = Alarm
9	Override position 1	Receive	1	1	1	0	1	1.003	_Enable	1 bit	---	0 = Disable 1 = Enable
10	Override position 2	Receive	1	1	1	0	1	1.003	_Enable	1 bit	---	0 = Disable 1 = Enable

<sup>1)</sup> For operating mode "heating / cooling control"

## Group Objects Description

- 1 Fault information If group object #3 "fault transmission" is set to "on", the following faults can be transmitted if they occur. In that case, group object #2 value changes to "alarm".

Error	Group obj. #1	Description	Resolution
Device jammed	XX 00 0A 03 0C 05	Target position can't be reached due to blockage.	Remove blockage (visual inspection required) or invert Opening direction, if it is set wrongly Or switch on adaptive positioning, if mechanical limits are intended.
Backup mode entered	XX 01 01 02 0C 05	Actuator is in backup mode (cf. respective parameter setting)	Actuator leaves Backup mode when receiving a setpoint.
Operating hours notification	XX 01 0A 04 0C 05	Appears after a cumulated motor running time of 365 days	Check device status and control loop sensitivity

- 2 Fault state Indicates whether the actuator is in fault state. If yes, read out group object #1.
- 3 Fault transmission Enabling/ disabling the fault transmission. Fault transmission is disabled by default; therefore no faults are transmitted from the actuator over the KNX bus.
- 4 Setpoint position / Setpoint pos. heating <sup>1)</sup> Setpoint 0...100% for valve position, depending on the operating mode.
- 5 Actual position / Actual pos.heating <sup>1)</sup> Actual value 0...100% for valve position, depending on the operating mode.
- 6 Setpoint pos. cooling <sup>1)</sup> Setpoint 0...100% for valve position, available in operating mode "Heating / cooling control".
- 7 Actual pos. cooling <sup>1)</sup> Actual value 0...100% for valve position, available in operating mode "Heating / cooling control".
- 8 Fault Same function as group object #2 (available for compatibility reasons).
- 9 Override position 1 When the object is triggered, the actuator drives to the override position 1 defined by the respective ETS parameter.
- 10 Override position 2 When the object is triggered, the actuator drives to the override position 2 defined by the respective ETS parameter.

## Technical data

Power supply		
Operating voltage	G..B111.9E/KN	AC 24 V ± 20% (SELV) or AC 24 V class 2 (US)
Frequency		50/60 Hz
Power consumption	at 50 Hz	
	Actuator holds	1 VA / 0.5 W
	Actuator rotates	3 VA / 2.5 W
Function data		
Positioning time for nominal rotation angle	G..B111.9E/..	150 s (50 Hz) 120 s (60 Hz)
Nominal torque	GDB..	5 Nm
	GLB..	10 Nm
Maximum torque	GDB..	< 7 Nm
	GLB..	< 14 Nm
Nominal / maximum rotation angle		90° / 95° ± 2°
Direction of rotation	Adjustable over bus (operating mode "position control")	Clockwise (CW) / Counter-clockwise (CCW)
Connection cables		
Cable length		0.9 m
Power supply	Number of cores and cross-sectional area	2 x 0.75 mm <sup>2</sup>
Communication	Number of cores and cross-sectional area	2 x 0.75 mm <sup>2</sup>
Communication		
Communication protocol	Connection type	KNX-TP (el. isolated)
	Bus load	5 mA
Degree of protection		
Degree of protection	Degree of protection acc. to EN 60529 (see mounting instruction)	IP54
Safety class	Safety class acc. to EN 60730	III
Environmental conditions		
Applicable standard		IEC 60721-3-x
Operation	Climatic conditions	Class 3K5
	Mounting location	Indoors
	Temperature general	0...50 °C
	Humidity (noncondensing)	5...95 % r. F.
Transport	Climatic conditions	Class 2K3
	Temperature	-25...70 °C
	Humidity	5...95 % r. h.
Storage	Climatic conditions	Class 1K3
	Temperature	-5...45 °C
	Humidity	5...95 % r. h.

<b>Directives and Standards</b>		
Product standard		EN 60730-x
Product family standard		EN 50491-2, EN 50491-3, EN 50491-5 General requirements for Home and Building Electronic Systems (HBES) and Building Automation and Control Systems (BACS)
Electromagnetic compatibility (Application)		For residential, commercial and industrial environments
EU Conformity (CE)		A5W00003842 <sup>1)</sup>
RCM Conformity		A5W00003843 <sup>1)</sup>
UL, cUL	AC 24 V	UL 873 <a href="http://ul.com/database">http://ul.com/database</a>

<b>Environmental compatibility</b>		
		The product environmental declaration A6V10209938 <sup>1)</sup> contains data on environmentally compatible product design and assessments (RoHS compliance, materials composition, packaging, environmental benefit, disposal).

<b>Dimensions / Weight</b>		
Weight	Without packaging	0.6 kg
Dimensions		71 x 158 x 61 mm

## Diagrams

### Internal diagram / Power supply and communication cables

The KNX rotary actuator is supplied with two prewired power supply and communication cables.

#### G..B111.9E/KN

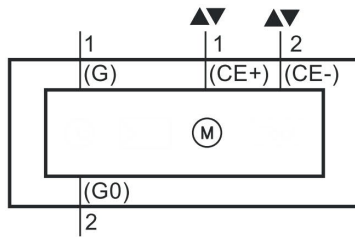

Core desig.	Core color	Terminal code	Description
Cable 1: Power / black sheathing			
1	red (RD)	G	System voltage AC 24 V
2	black (BK)	G0	System neutral AC 24 V
Cable 2: KNX / green sheathing			
1	red (RD)	CE+	KNX CE+
2	black (BK)	CE-	KNX CE-

### Note

The operating voltage at terminals G and G0 must comply with the requirements under SELV or PELV.

Safety transformers with twofold insulation as per EN 61558 required; they must be designed to be on 100 % of the time.

## Dimensions

#### G..B111.9E/KN

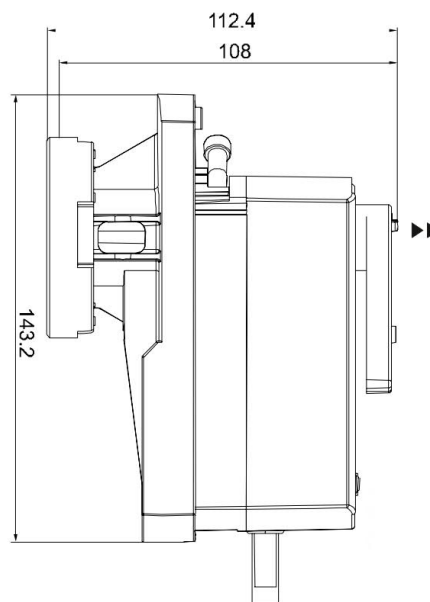
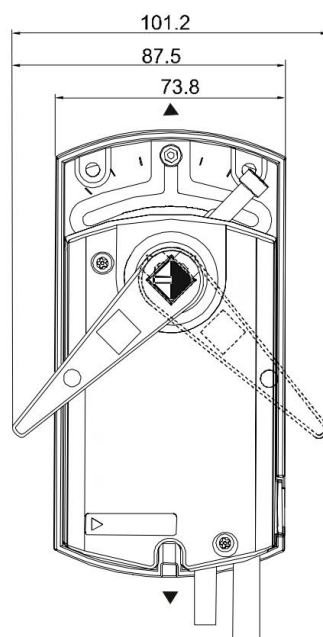

Minimum distance from walls or ceilings during mounting, wiring, operation, etc.

▶ = > 100 mm

▶▶ = > 200 mm

Dimensions in mm