

ПРЕДПРИЯТИЕ МАКСАЭРО

- Производство воздуховодов и систем вентиляции
- Клапаны противопожарные
- Клапаны дымоудаления
- Вентиляторы общепром, дымоудаления, крышные

220056, г. Минск, ул. Стариновская, 15

Тел./факс: +375 17 244-67-44, 258-67-51, 347-73-56, 252-54-27

Velcom: +375 29 603-88-99

E-mail: olegaero@yandex.by

www.maxaero.by



Противопожарный клапан CFDM 250



These technical specifications state a row of of fire dampers (further only dampers) CFDM - DN 250.
It is valid for production, designing, ordering, delivery, assembly and operation.

I. CONTENT

II. GENERAL INFORMATION	3
1. Description.....	3
2. Design.....	4
3. Dimensions and weights.....	5
4. Placement and Assembly.....	6
5. Statement of installations.....	7
III. TECHNICAL DATA	9
6. Pressure loss.....	9
7. Coefficient of local pressure loss.....	9
IV. MATERIAL, FINISHING	10
8. Material.....	10
V. INSPECTION, TESTING	10
9. Inspection, testing.....	10
VI. TRANSPORTATION AND STORAGE	10
10. Logistic terms.....	10
VII. ASSEMBLY, ATTENDANCE, MAINTENANCE AND REVISIONS	10
11. Assembly.....	10
12. Entry into service and revisions.....	10
VIII. DATA OF PRODUCT	11
13. Data label.....	11
IX. ORDERING INFORMATION	11
14. Ordering key.....	11

II. GENERAL INFORMATION

1. Description

- 1.1.** Fire dampers are shutters in duct systems of air-conditioning devices that prevent spreading the fire and combustion products from one fire segment to the other one by means of closing the air duct in the points of fire separating constructions.

Dampers blade automatically closes air duct using a shutting spring.

The damper is sealed with a plastic foam packing against smoke penetration after closing the blade. At the same time, the damper blade is bedded in a material which enlarges its capacity and air-proofs the air duct.

Fig. 1 CFDM - DN 250



- 1.2.** Damper characteristics

- CE certified acc. to EN 15650
- Tested in accordance with EN 1366-2
- Classified acc. to EN 13501-3+A1
- Fire resistance EIS 90
- Internal leakage class 2 acc. to EN 1751, external leakage is equal to ducting system
- Corrosion resistant acc. to EN 15650
- ES Certificate No. 1391-CPR-2021/0075
- Declaration of Performance No. PM/CFDM250/01/21/1
- Hygienic assessment of fire dampers - Report No. 1.6/pos/19/19b

- 1.3.** Working conditions

Exact damper function is provided under the following conditions:

- a) Maximum air circulation speed: 12 m/s
Maximum pressure difference: 1200 Pa
- b) The air circulation in the whole damper section must be secured as steady on whole surface.

Operation of the damper does not depend on the direction of air circulation. The dampers can be located in an arbitrary position.

Dampers are suitable for ventilation systems, where air does not contain any abrasive, chemical or adhesive particles.

Dampers are designed for macroclimatic areas with mild climate according to EN 60 721-3-3. Temperature in the place of installation is permitted to range from -30°C to +50°C.

2. Design

2.1. Design with mechanical control

Design .01

Design with mechanical control with a thermal protective fuse (inner mechanical control) which actuates the shutting device within 120 seconds at latest after the nominal start temperature 72°C has been reached. Automatic initiation of the shutting device is not activated if the temperature does not exceed 70°C.

Damper in design .01 with mechanical control can be equipped by one or two limit switches signalling position of the damper blade "CLOSED".

Fig. 2 Design .01



Design .11, .15

Design .01 with mechanical control can be equipped by one or two limit switches signalling position of the damper blade "CLOSED". Connection wires of the end-switches of CFDM fire dampers are done through the bushing opening in the air-duct.

Fig. 3 Design .11, .15

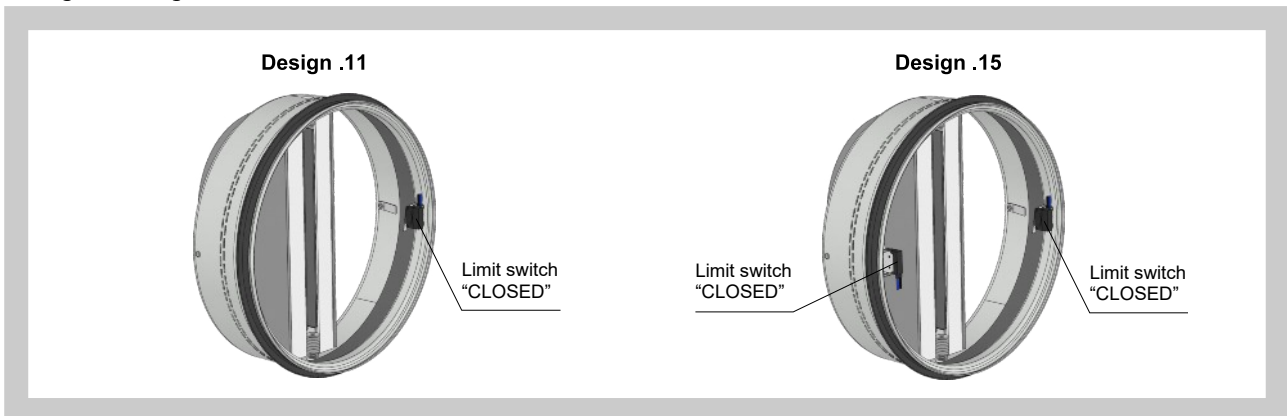

Fig. 4 Limit switch G905-300E05W1

1(COM) - black wire
2(NC) - gray wire
4(NO) - blue wire

Nominal voltage and maximal current	AC 230V / 5A
Class of protection	IP 67
Working temperature	-25°C ... +120°C

This limit switch is possible to connect in following two versions:
 a) **CUT-OFF** if the arm is moving ... connect wire 1+2
 b) **SWITCH-ON** if the arm is moving ... connect wire 1+4

3. Dimensions and weights

3.1. Dimensions

Fig. 5 CFDM

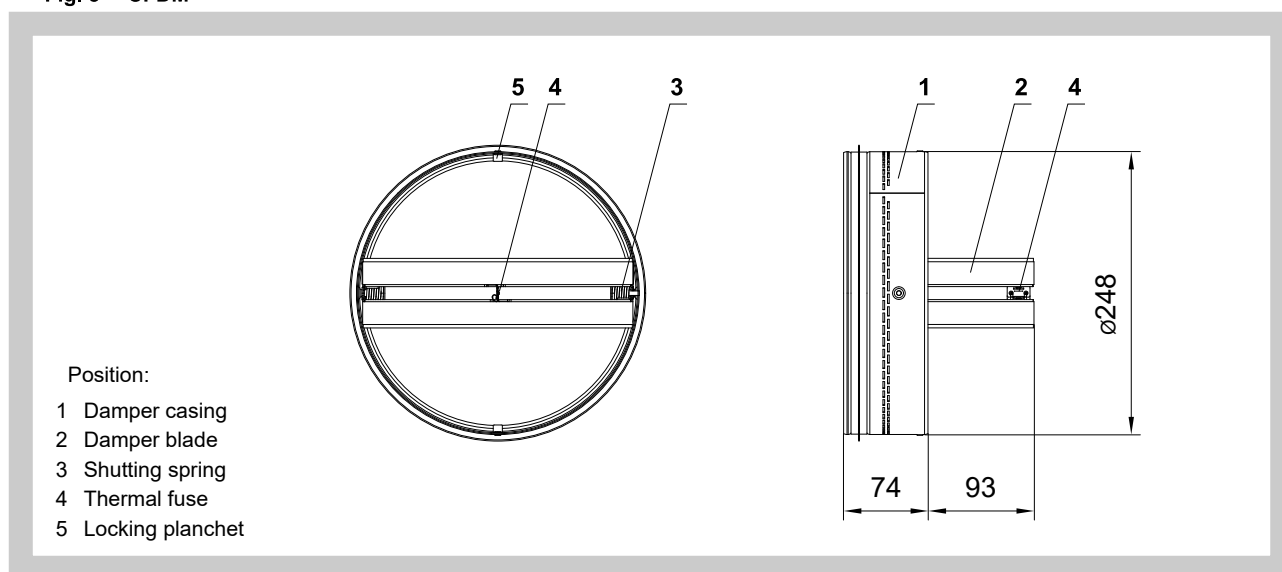

3.2. Weights and effective area

Tab. 3.2.1. Weights and effective area

Size øD [mm]	Weight [kg]	Effective area S_{ef} [m ²]
250	1,56	0,0309

4. Placement and Assembly

- 4.1. Fire dampers are suitable for installation in arbitrary position in vertical and horizontal passages of fire separating constructions. Duct assembly procedures must be done so as all load transfer from the fire separating constructions to the duct in the placement of fire damper installation is absolutely excluded. Installation gap must be filled by approved material perfectly in all the installation space volume (installation gap).

To provide needed access space to the control device, all other objects must be situated at least 350 mm from the control parts of the damper. Inspection hole must be accessible.

Notice: Damper has to be accessible for regular checks and maintenance.

Fire damper is inserted inside the duct. Blade has to be inside of fire separating construction (after closing).

The distance between the fire damper and the construction (wall, ceiling) must be at least 75 mm. In case that two or more dampers are supposed to be installed in one fire separating construction, the distance between the adjacent dampers must be at least 200 mm according to EN 1366-2 paragraph 13.5.

Fig. 6 Distance between the fire damper and construction

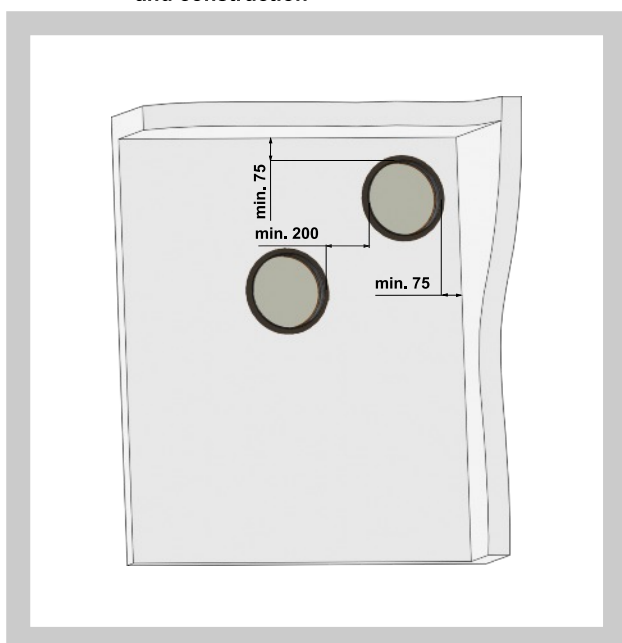
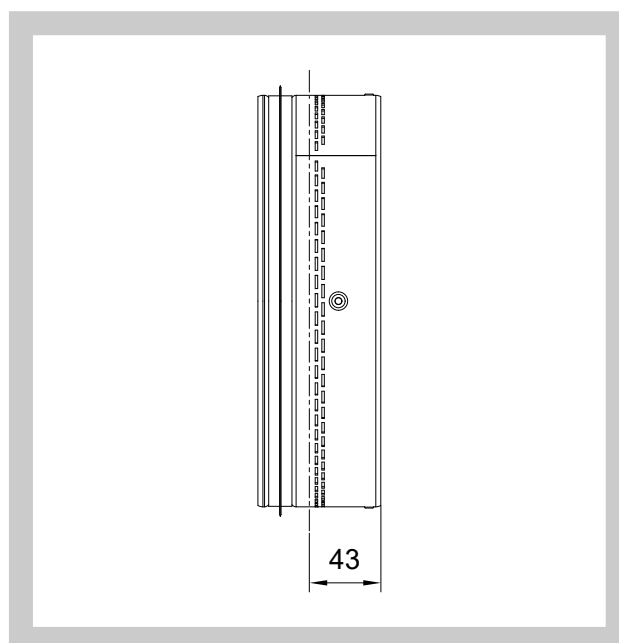
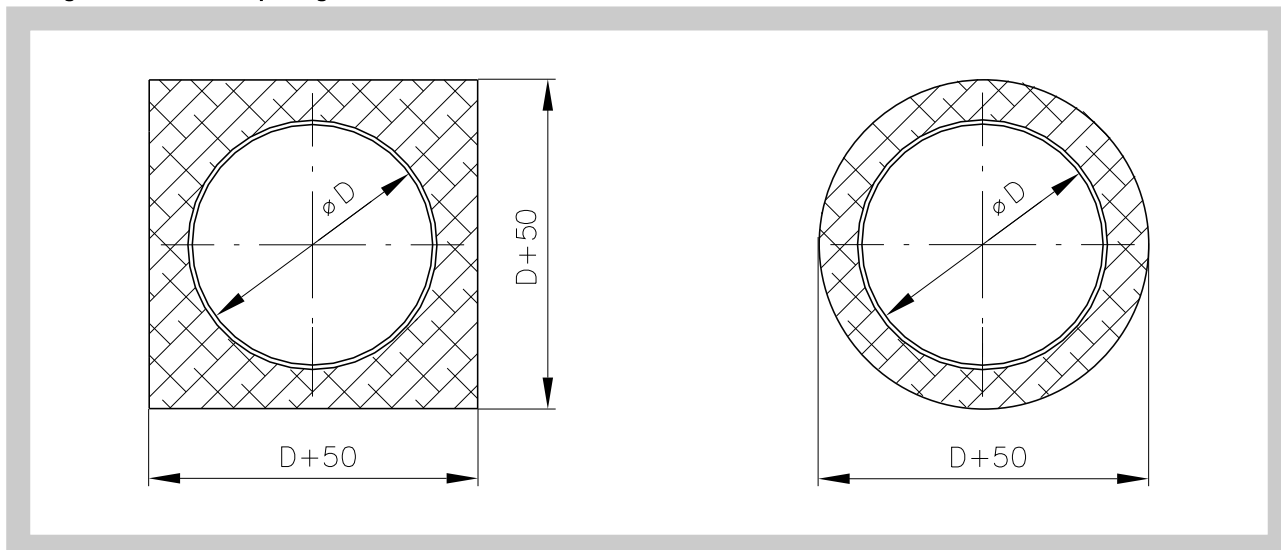

Fig. 7 Blade axis



- 4.2. Installation opening dimensions

Fig. 8 Installation opening dimensions



4.3. Examples of fire damper installing

The fire damper can be integrated into a solid ceiling construction made e.g. of normal concrete with minimum thickness 110 mm or porous concrete with minimum thickness 125 mm.

5. Statement of installations

5.1. Statement of installations the fire dampers

Tab. 5.1.1. Statement of installations

Construction	Installation	Material of stuffing box	Page
Solid wall construction	Wet	mortar or gypsum	8

Fig. 9 Solid ceiling construction - mortar or gypsum

EIS 90

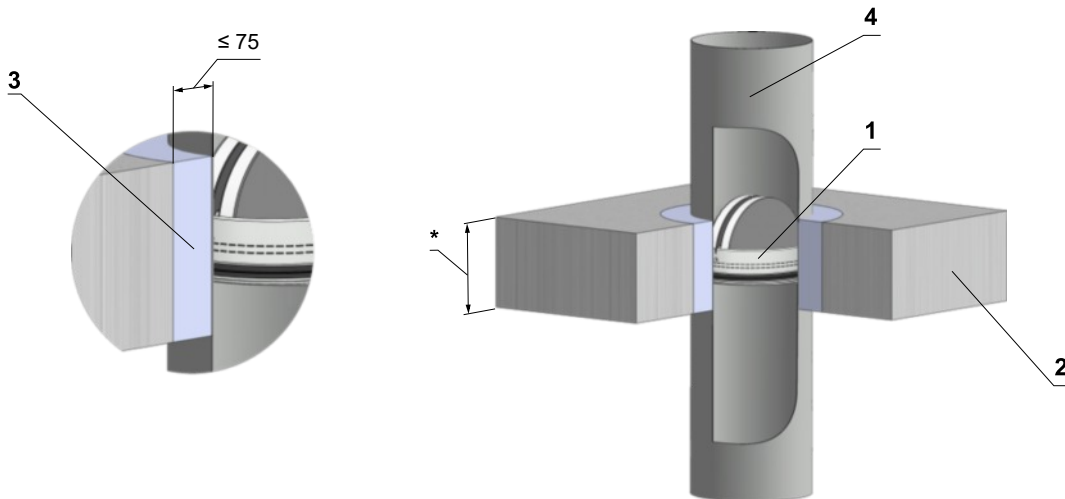
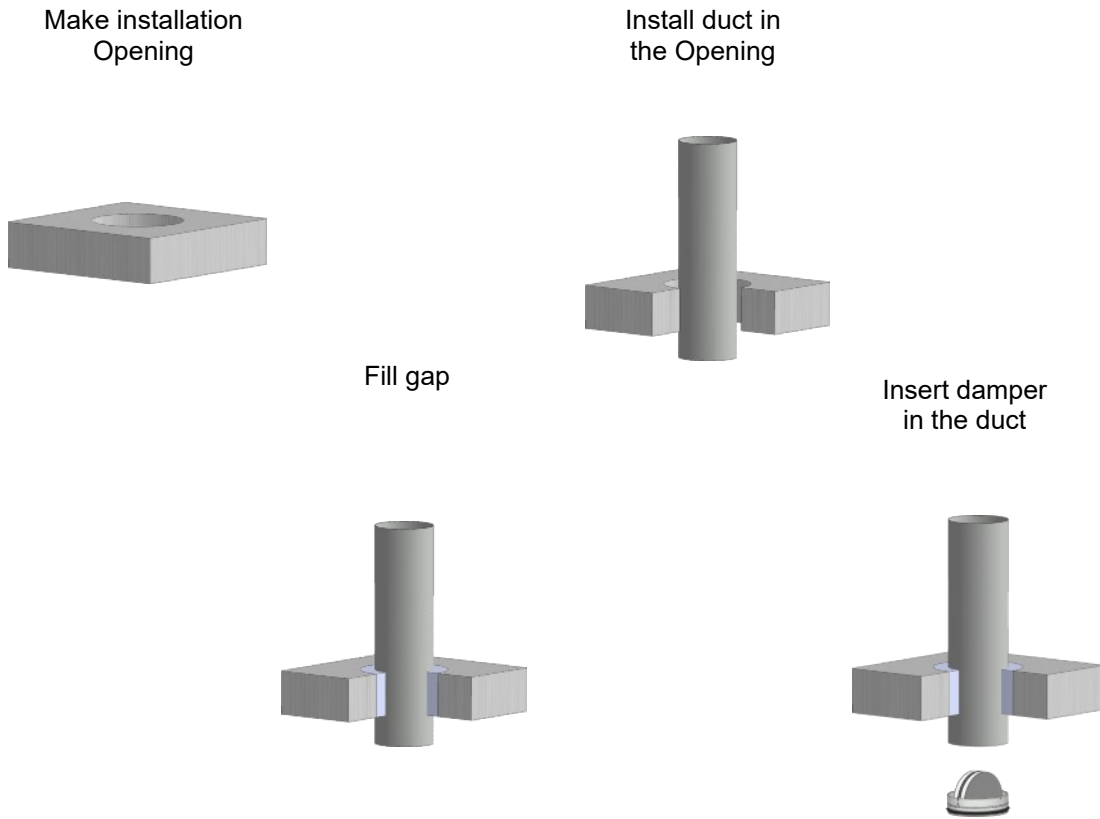

* min. 110 - Concrete/ min. 125 - Aerated concrete

Position:

- 1 Fire damper
- 2 Solid wall construction
- 3 Mortar or gypsum
- 4 Steel duct

III. TECHNICAL DATA

6. Pressure loss

6.1. Pressure loss calculation

$$\Delta p = \xi \cdot \rho \cdot \frac{w^2}{2}$$

- Δp [Pa] pressure loss
- w [m.s⁻¹] air flow speed in nominal damper section
- ρ [kg.m⁻³] air density
- ξ [-] coefficient of local pressure loss for the nominal damper section

6.2. Determination of pressure loss by using Diagram 1 $\rho = 1,2 \text{ kg.m}^{-3}$ and noise data

Diagram 1 Pressure losses for air density $\rho = 1,2 \text{ kg.m}^{-3}$

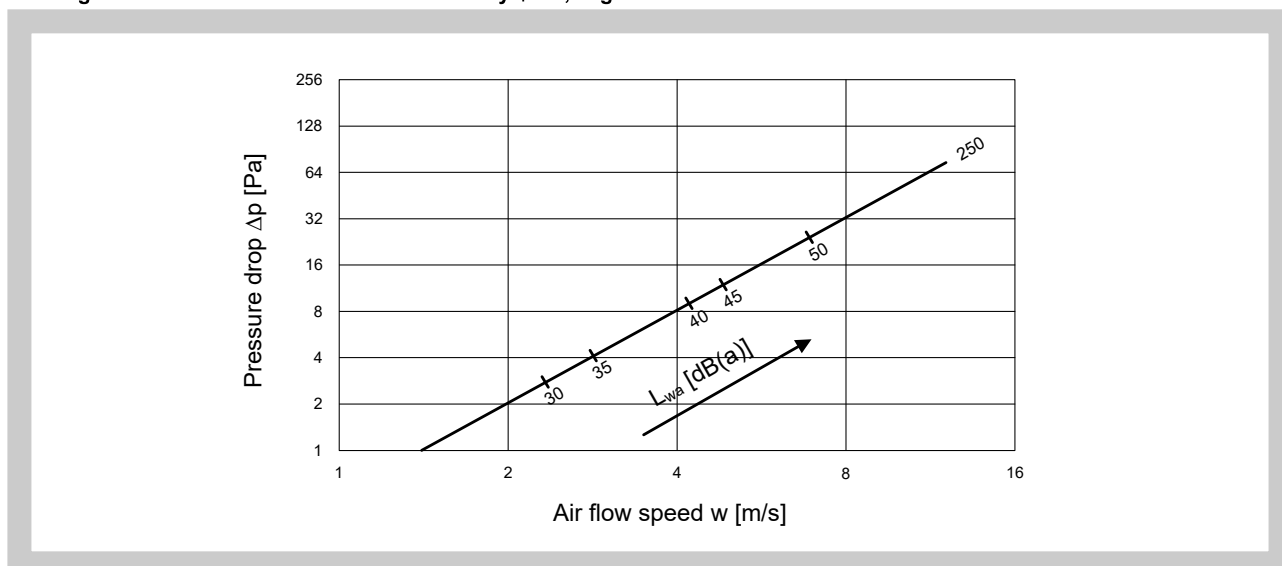

7. Coefficient of local pressure loss

7.1. Coefficient of local pressure loss ξ (-)

Tab. 7.1.1. Coefficient of local pressure loss [m/s]

D	250
ξ	0,738

IV. MATERIAL, FINISHING

8. Material

- 8.1.** Damper casing are supplied in the design made of galvanized sheet without any other surface finishing.
Damper blades are made of fire resistant asbestos free boards made of mineral fibres.
Damper controls are made of stainless steel with no other surface finish.
Springs are made of stainless steel.
Thermal protective fuses are made of sheet brass, thickness = 0,5 mm.
Fasteners are galvanized.
- 8.2.** According to the customer's requirements damper casing can be finished by color acc. RAL.
- 8.3.** Damper are not manufactured in stainless steel.

V. INSPECTION, TESTING

9. Inspection, testing

- 9.1.** The appliance is constructed and preset by the manufacturer, its operation is dependent on proper installation and adjustment.

VI. TRANSPORTATION AND STORAGE

10. Logistic terms

- 10.1.** Dampers are transported by box freight vehicles without direct weather impact, there must not occur any sharp shocks and ambient temperature must not exceed +40°C. Dampers must be protected against mechanic damages when transported and manipulated. During transportation, the damper blade must be in the "CLOSED" position.
- 10.2.** Dampers are stored indoor in environment without any aggressive vapours, gases or dust. Indoor temperature must be in the range from -5°C to +40°C and maximum relative humidity 80% (avoid condensation on the damper body). Dampers must be protected against mechanic damages when transported and manipulated.

VII. ASSEMBLY, ATTENDANCE, MAINTENANCE AND REVISIONS

11. Assembly

- 11.1.** All effective safety standards and directives must be observed during fire damper assembly.
- 11.2.** To ensure reliable fire damper function it is necessary to avoid blocking the closing mechanism and contact surfaces with collected dust, fibre and sticky materials and solvents.

12. Entry into service and revisions

- 12.1.** Before entering the dampers into operation after their assembly and by sequential checks, the following checks must be carried out.
Visual inspection of proper damper integration, inside damper area, damper blade, contact surfaces and silicon sealing.
- 12.2.** It is recommended to provide periodical checks, maintenance and service actions on Fire Equipment by Authorized persons schooled by Producer.

VIII. DATA OF PRODUCT

13. Data label

13.1. Data label is placed on the casing of fire damper.

Fig. 10 Data label

MANDÍK	MANDÍK, a.s. 267 24 Hostomice Czech Republic	Dobříšská 550 Czech Republic	CFDM	Požární klapka / Fire damper / Brandschutzklappe / Clapet coupe-feu
Klasifikace / Classification / Feuerwiderstand / Classification			EI90 (ve, ho-i↔o)S	
Certifikace / Certificate / Zulassungs-Nr. / Certifikat			1391-CPR-2021/0075	
Rozměr / Size / Grösse / Taille			250	EN 15650:2010
Výr. číslo / Serial number / Fert. Nr. / Numéro de serie				
Provedení / Design / Ausführung / Conception			.01	EIS 90  1391
Hmotnost / Weight / Gewicht / Poids			1,56	

IX. ORDERING INFORMATION

14. Ordering key

14.1. Fire damper

CFDM 250 - .11/90

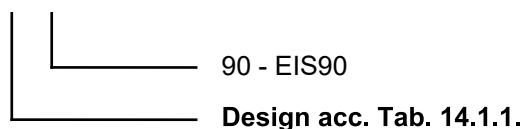

Tab. 14.1.1. Damper design

Damper design	Additional digit
Thermal with inner mechanical control	.01
Thermal with inner mechanical control and limit switch („CLOSED“)	.11
Thermal with inner mechanical control and two limit switches („CLOSED“)	.15