

ПРЕДПРИЯТИЕ МАКСАЭРО

- Производство воздуховодов и систем вентиляции
- Клапаны противопожарные
- Клапаны дымоудаления
- Вентиляторы общепром, дымоудаления, крышные

220056, г. Минск, ул. Стариновская, 15

Тел./факс: +375 17 244-67-44, 258-67-51, 347-73-56, 252-54-27

Velcom: +375 29 603-88-99

E-mail: olegaero@yandex.by

www.maxaero.by



Газовый тепловоздушный агрегат MONZUN-CP



This manual is an part of the product and must be handed over to the end user together with the equipment.

- a) Gas hot-air heaters MONZUN-CP may only be used by a person instructed in using the device in a safe manner and who understands possible hazards.
- b) Persons with reduced physical or mental abilities or person that lack of experience and knowledge may only use the heater under the supervision of a person instructed under point (a).
- c) Children can not use or play with the gas hot-air heaters MONZUN-CP.

I. CONTENT

II. GENERAL	3
1. Description of heaters MONZUN-CP.....	3
2. Description of function.....	3
3. Dimensions and weights.....	4
4. Versions.....	4
III. TECHNICAL DATA	5
5. Technical parameters.....	6
6. Material, surface treatment.....	6
IV. INSTALLATION	7
V. FLUE GAS EXHAUST AND COMBUSTION AIR SUPPLY	8
7. Pressure losses.....	8
8. Examples of flue gas exhaust and combustion air supply solutions.....	9
VI. INSTALLATION CONDITIONS	10
9. Installation principles.....	10
10. Gas connection installation.....	10
11. Electrical installation.....	11
12. Condensate drain.....	11
VII. OPERATION AND MAINTENANCE	11
13. Commissioning.....	12
14. Decommissioning.....	12
15. Maintenance.....	12
16. Failures and their elimination.....	13
VIII. INSTALLATION AND DISASSEMBLY OF COMPONENTS	14
17. Conversion to another type of fuel.....	16
18. Components used in heaters MONZUN-CP.....	17
19. Recycling and disassembly at end of service life.....	17
IX. CONTROL	18
20. Wiring diagram.....	18
21. Control box.....	21
X. CHECKING AND TESTING	21
XI. LOGISTIC DATA	21
XII. PRODUCT DATA	22
22. Data label.....	22
XIII. ORDERING DATA	22
23. Ordering key.....	22
XIV. OPTIONAL ACCESSORIES	23
24. Mixing chamber.....	23
25. Fixed console.....	24
26. Swivel console.....	24
27. Roof section.....	24
28. Roof warhead.....	25
29. Passage part.....	25
30. Rain protection louver PDZM.....	25
XV. PRODUCT DATA ACCORDING TO COMMISSION REGULATION (EU) 2021/1188	26

MONZUN-CP air heaters meet the ecodesign requirements of ErP 2021 according to Commission Regulation (EU) 2016/2281

CE 1015

II. GENERAL

1. Description of heaters MONZUN-CP

Hot air gas heaters MONZUN-CP are designed for ventilation and ecological heating of rooms and halls by heated air. Available versions are in a power range from 15 kW to 60 kW with an airflow from 2200 to 5000³m /h in size: 15, 20, 30, 40, 50 and 60. In terms of gas extraction equipment, it is an open or closed appliance with forced exhaust flue gas.

Appliance categories - I_{2H}, I_{2E}, I_{2L}, I_{3B/P}, I_{3P}, I₃₊

Design B₂₃, C₁₃, C₃₃, C₆₃

Emission value NO_x to 70 mg/kWh acc. to commission regulation (EU) 2016/2281 (Ekodesign 2021)

Emission class - NO_x 5

A common operating fuel for MONZUN-CP units are:

- natural gas – ZP (G20/G25)
- propane-butane – PB (G30/G31)
- propane – P (G31)

The MONZUN-CP heaters are in the standard version intended for installation in weather-protected environments of class 3K3 according to EN 60721-3-3 with temperature range from 0° to +35 °C, for spaces without explosion hazard according to EN 1127-1. The air passing through the unit and the combustion air must not contain solid, fibrous, sticky or aggressive particles. They cannot be installed in rooms where there is a risk of fire or explosion.

MONZUN-CP units in version B23 must have a sufficient amount of combustion air, at least 1,6 m³/h for every 1 kW of installed power input of MONZUN-CP heaters.

The control of the power output of the MONZUN-CP heaters is continuous from minimum power to rated / maximum power. The heated air flow is forced by an axial fan.

Condensate drainage must be installed on the units! The condensate neck is equipped with an external thread G1/2".

2. Description of function

The heater operation is controlled by the control automatics.

After the heater is switched on, the burner fan starts to ventilate and the exchanger is ventilated with fresh air for 30 s.

After the venting time, starting speed of the burner fan is set by the the control automatics, the burner electrical ignition is triggered and the electromagnetic gas valve is opened. After the burner is ignited, the speed of the burner fan is adjusted to the operating speed according to the required power.

When the heater exchanger is heated to the set temperature, the fan operating thermostat triggers the axial air fan and the heater starts to blow heated air.

When the heater is switched off, the control unit automatically closes the electromagnetic gas valve, the speed of the burner fan is adjusted to the ventilating speed and the exchanger is ventilated with fresh air. The axial air fan keeps running and ensures that the exchanger cools down below the set temperature.

The function of the burner fan is monitored by the control automatics with the help of the fan motor speed sensor.

The temperature of the exchanger is monitored by thermostats:

- Operating thermostat of ventilator (switches the axial fan ON and OFF according to set temperature)
- Burner operating thermostat (checks the correct temperature of the heat exchanger, if the set temperature is exceeded, its shuts down the burner operation)
- Emergency thermostat (checks the maximum allowable temperature of the heat exchanger and when this limit temperature is reached, shuts down the gas burner and activates the warning light. Operator intervention is required to unblock the emergency thermostat. Operator should check the heater and unblock the emergency thermostat.)

The throughput of the exhaust system and the supply of combustion air is monitored by a manostat, which switches off the heating when the pressure loss is exceeded.

The control of the output power of the hot-air heater is carried out by the control signal 0–10 V (DC ±), applied to the modulating terminals of the heater. If the control signal is not connected, after the heater is switched on by the service switch, the heater switches to minimum power output.

The heater can operate in condensing mode. The condensate drain from the exchanger is equipped with a siphon with level control. When the condensate level in the siphon rises, eg due to a clogged drain, the burner of the unit is switched off until the condensate level drops

Pic. 1 Signalization of functions

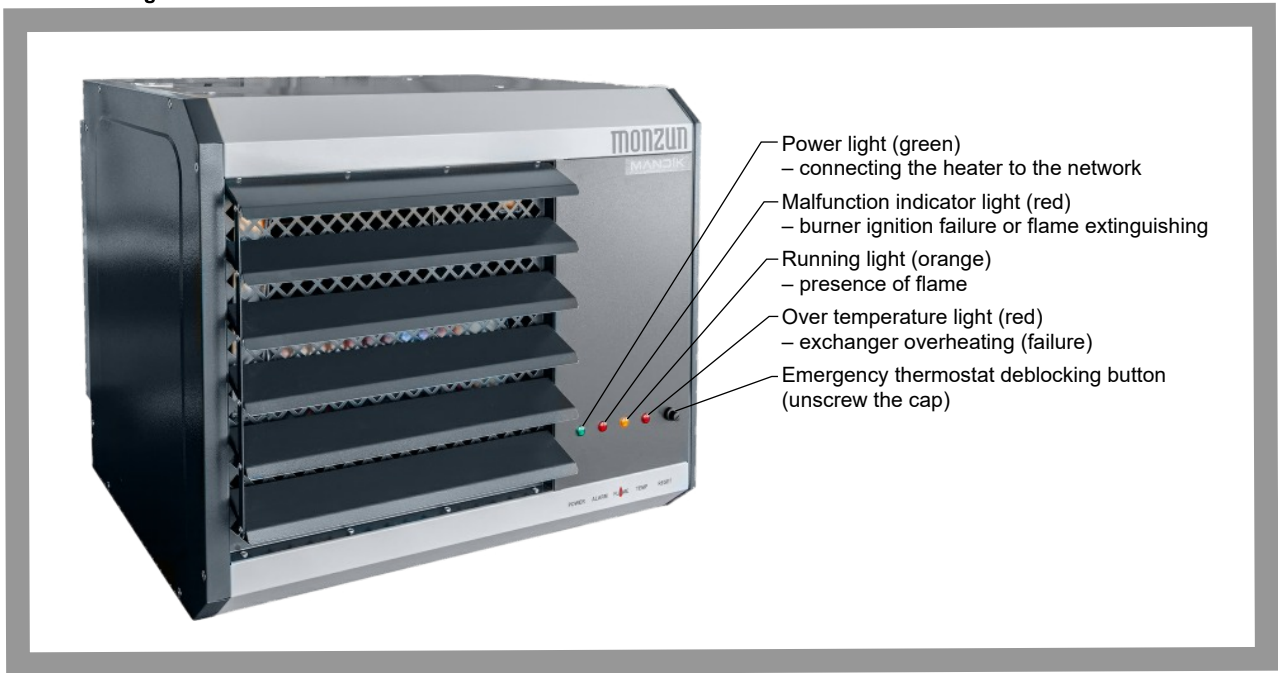

3. Dimensions and weights

Pic. 2 Dimensions of MONZUN-CP heaters

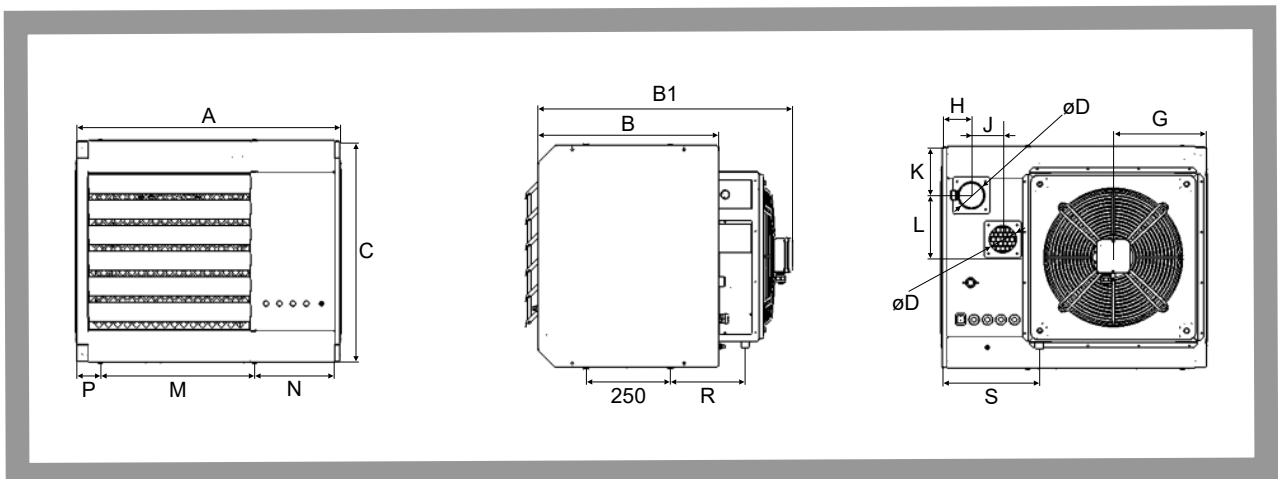

Pic. 3 Dimensions of MONZUN-CP heaters, with flange

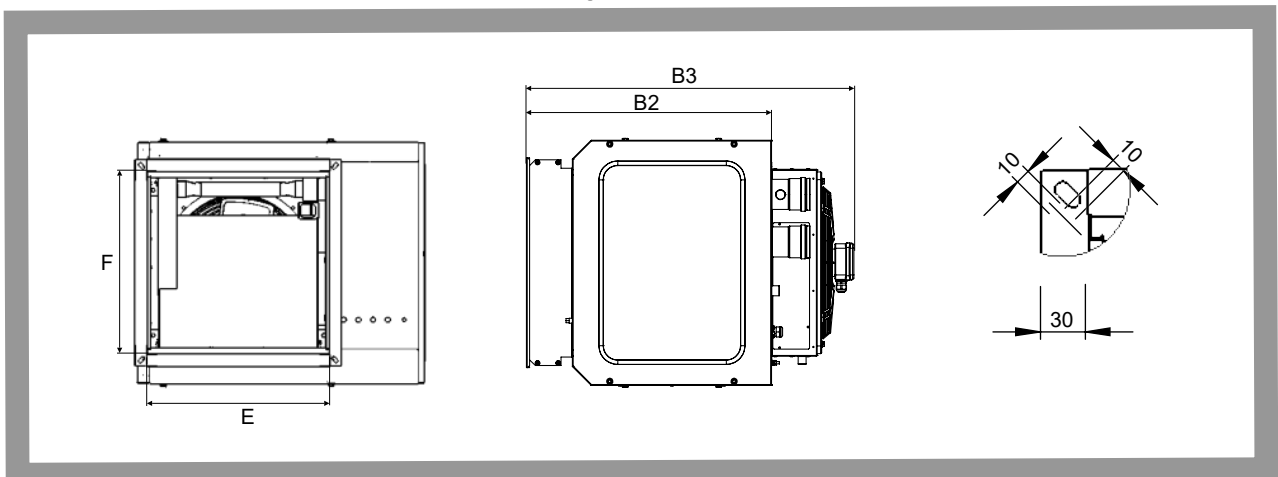

Tab. 2.1 Dimensions and weights of MONZUN-CP heaters

Performance series	15, 20	30, 40	50, 60
dimension A [mm]	785	995	1200
dimension B [mm]	533	533	533
dimension B1 [mm]	735	775	815
dimension B2 [mm]	665	662	666
dimension B3 [mm]	807	904	948
dimension C [mm]	655	685	733
dimension D [mm]	80	80	100
dimension E [mm]	500	710	900
dimension F [mm]	500	500	560
dimension H [mm]	90	90	90
dimension J [mm]	93	114	108
dimension K [mm]	143	163	202
dimension L [mm]	130	112	143
dimension G [mm]	277	381	483
dimension M [mm]	458	668	668
dimension N [mm]	255	255	255
dimension P [mm]	72	72	275
dimension R [mm]	223	227	267
dimension S [mm]	292	342	383
design Z, V, P - heater weight [kg]	66	90	116
design Z, P - the weight of the heater with the transport package [kg]	81	106	136
design K - heater weight [kg]	53	72	93

4. Versions

MONZUN-CP heaters are available in these designs:

- For horizontal mounting with discharge louver
- For horizontal mounting with discharge flange - version P
- For installation in air handling units - design K

MONZUN-CP heaters in design K do not have blinds, diffusers, fan or fan carrier and may only be used as part of air handling units.

Pic. 4 Main parts of the MONZUN-CP heater

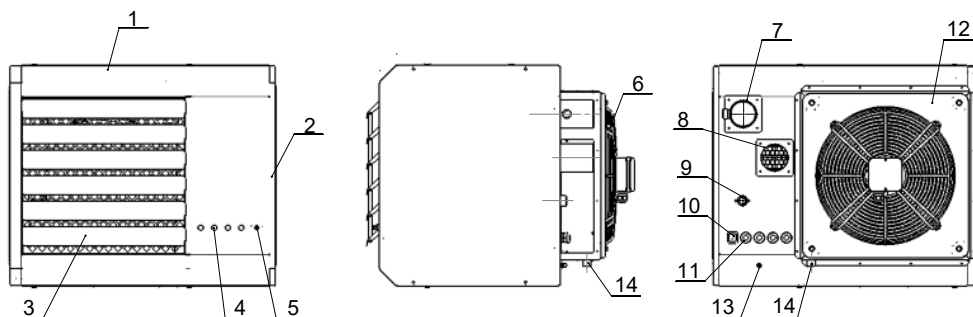

1. Cabinet of the heater
2. Burner chamber side door
3. Tilting blinds (In design V, the direction of the blinds is different)
4. Indicators (power supply, error, running, overheating)

5. Emergency thermostat
6. Axial fan
7. Flue gas outlet
8. Combustion air inlet
9. Gas connection

10. Service switch
11. Grommet: PG 13,5 – 4 pcs
12. Fan carrier
13. Grounding screw

III. TECHNICAL DATA

5. Technical parameters

Tab. 3.1 Technical parameters of heaters MONZUN-CP

Performance series	15	20	30	40	50	60
Rated power input H_i [kW]						
Fuel G20 – ZP	16,4	21,0	31,0	40,0	49,3	59,9
Fuel G25 – ZP	16,4	21,0	31,0	38,4	49,3	59,8
Fuel G31 – propane	16,3	21,0	31,0	38,8	51,3	60,2
Fuel G30 – butane	16,4	21,0	31,0	38,4	49,6	59,9
Rated heating output [kW]						
Fuel G20 – ZP	15,2	19,6	29,6	35,6	46,2	55,0
Fuel G25 – ZP	15,3	19,6	29,2	35,7	46,1	54,7
Fuel G31 – propane	15,2	19,9	28,8	36,3	47,1	54,9
Fuel G30 – butane	15,3	19,3	29,1	35,2	46,2	54,8
Minimum heating output [kW]						
Fuel G20 – ZP	4,2	4,2	7,2	7,2	13,0	13,0
Fuel G25 – ZP	4,3	4,3	7,5	7,5	13,3	13,3
Fuel G31 – propane	4,2	4,2	7,7	7,7	13,3	13,3
Fuel G30 – butane	4,4	4,4	7,4	7,4	13,6	13,6
Gas consumption at nominal power						
G20 – ZP [m ³ /h]	1,70	2,23	3,30	4,06	5,54	6,20
G25 – ZP [m ³ /h]	2,03	2,65	3,92	4,82	7,57	7,36
G31 – propane [kg/h]	1,35	1,75	2,66	6,50	4,44	5,25
G30 – butane [kg/h]		1,65	2,44	7,98	3,91	4,72
Gas consumption at minimum power						
G20 – ZP [m ³ /h]	0,42	0,42	0,70	0,70	1,32	1,32
G25 – ZP [m ³ /h]	0,54	0,54	0,88	0,88	1,76	1,76
G31 – propane [kg/h]	0,40	0,40	0,60	0,60	1,30	1,30
G30 – butane [kg/h]	0,34	0,34	0,56	0,56	1,03	1,03
Connecting overpressure						
G20 – ZP [mbar]	17 - 26					
G25 – ZP [mbar]	25 - 30					
G31 P [mbar]	30 - 50					
G30/31 PB [mbar]	30 - 50					
Electrical connection [V/Hz]	230/50					
IP protection	IP40					
Power input [kW]	0,22	0,22	0,45	0,45	0,58	0,58
Fuse [A]	4					
Air flow [m ³ /h]	2400	2400	4000	4000	6000	6000
Air flow range in free space, residual speed 0,25 m/s [m]	12,0	12,0	14,0	14,0	24,0	24,0
Increase air temperature at Rated power [°C]	19,0	24,3	22,0	26,0	22,1	27,1
Average sound level at 1 m from the device in free acoustic field [dB (A)]						
	58,4	58,4	63,5	63,5	68,6	68,6

6. Material, surface treatment

The heater housing is made of galvanized steel sheet, powder coated, the assembly of individual sheet metal parts is made with screws and blind rivets.
The heater exchanger is made of stainless steel.

IV. INSTALLATION

The minimum distance between the surface of the heater and other surfaces is indicated on the picture below. The minimum distance between the non insulated flue duct and flammable materials is 200 mm.

Pic. 5 Minimal space for installation on the wall

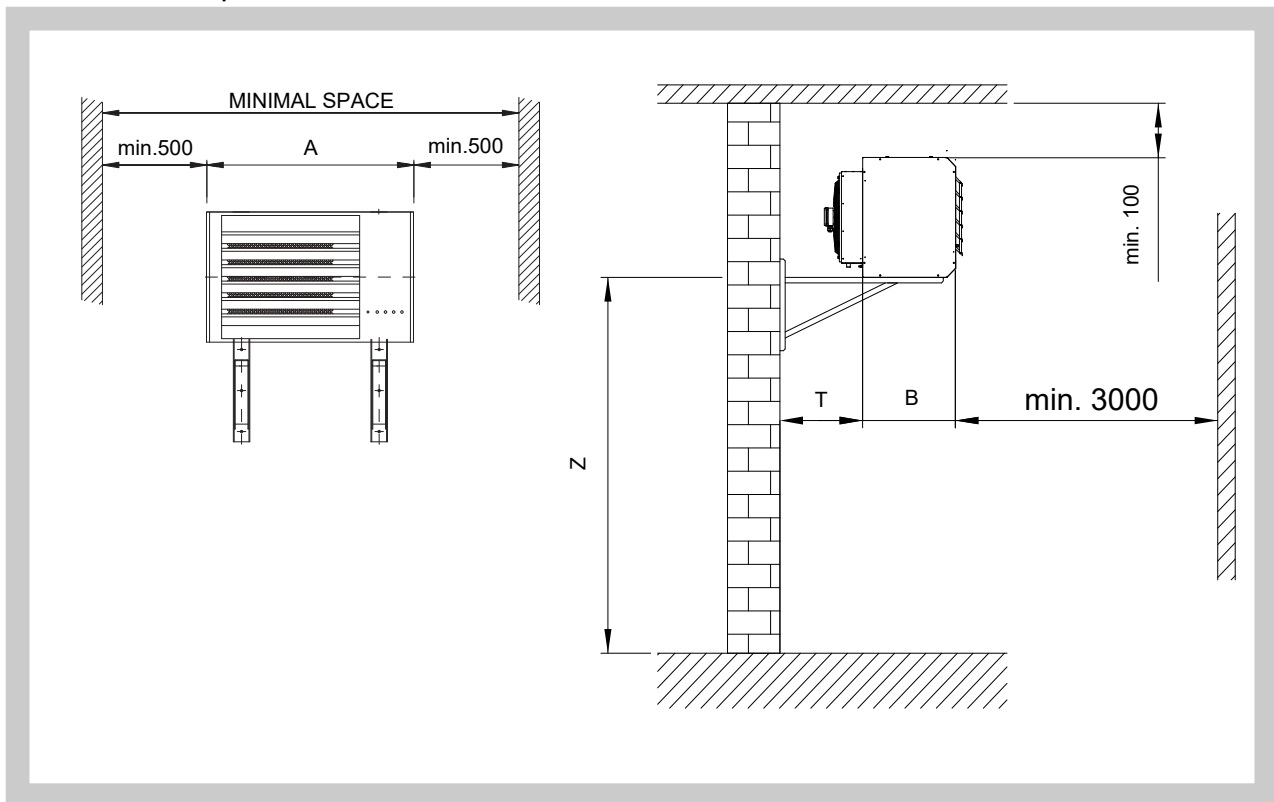

Tab. 4.1 Heater MONZUN-CP, MONZUN-CP V – mounting dimensions

Heater MONZUN	Dimensions [mm]			
	A	B	T	Z
15, 20	785	533	440	2200
30, 40	995	533	440	2500
50, 60	1200	533	440	3000

The MONZUN-CP heater has four suspension points on the upper panel and four suspension points on the lower panel, which are fitted with M8 bolts, for which it is attached to a supporting structure, eg on a bracket. Select the location of the MONZUN-CP heaters so that the entire space is ventilated.

Pic. 6 Examples of installation of MONZUN-CP heaters in heated space

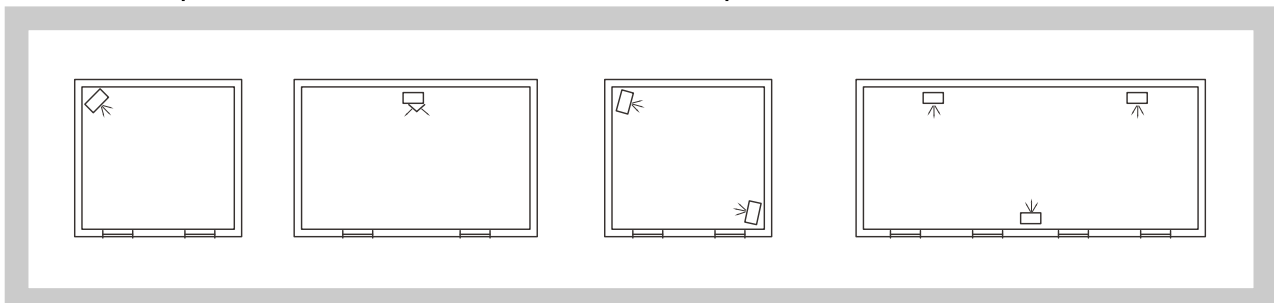

V. FLUE GAS EXHAUST AND COMBUSTION AIR SUPPLY

The flue gas exhaust is forced out of the building by the flue gas duct.

The device is categorized according to the method of flue gas exhaust B23, C13, C33 and C63 – acc. EN 1020.

The design and installation of the flue gas pipe must comply with the relevant standard.

The flue gas outlet in version C63 must be assembled from a system approved for appliances in version C6 and operation with condensate.

The MONZUN-CP premix burner fan together with the gas valve and Venturi tube ensures a constant fuel / air mixing ratio over the entire power output range.

If the pressure losses in the flue gas system and the combustion air supply are too high, the transported quantity of the mixture is reduced and the burner power output is reduced. The clogging will shut down the heater.

The maximum flue gas temperature at the heater outlet does not exceed 200 °C.

The heater is equipped with two (female) necks, one for flue gas connection and one for air intake.

Flue gas discharge can be realized:

- flue gas duct terminated by end cap
- coaxial chimney, which simultaneously removes flue gas and air intake for combustion

Combustion air can be sucked in:

- from the area where the heater is located
- from outside using piping for suction
- coaxial chimney, which simultaneously removes flue gas and air intake for combustion

The sum of the pressure loss values of the air intake and flue gas system can not exceed 100 Pa – see Tab. 5.1. Flue exhaust through the wall / ceiling from combustible materials isn't admissible.

7. Pressure losses

Tab. 5.1 Pressure losses of components for exhausting flue gases and suction of the air – stainless steel system

MONZUN	Nominal size (mm)	Pressure loss (Pa)										
		Tube 1 bm	Bend 45°	Bend 90°	RKN 90°	Coaxial chimney horizont.	Coaxial chimney vertical	Exhaust head Horizont.	Exhaust head vertical	Flexo Al pipe 1 bm	Flexo INOX 1 bm	Flexo Al Air intake 1 bm
15	DN 80	2,0	2,5	4,0	8,0	28,0	37,0	6,0	7,0	8,0	4,0	5,0
	DN 100	1,5	1,5	2,0	4,0	16,0	23,0	3,0	4,0	5,0	2,0	3,0
20	DN 80	3,5	4,0	6,0	11,0	40,0	51,0	10,0	12,0	14,0	6,0	8,0
	DN 100	2,0	2,0	2,0	6,0	21,0	28,0	5,0	6,0	7,5	3,0	4,5
30	DN 80	5,0	6,0	9,0	16,0	55,0	75,0	18,0	24,0	26,0	9,0	12,0
	DN 100	3,0	3,0	5,0	10,0	27,0	33,0	7,0	9,0	11,0	5,0	6,0
40	DN 80	8,0	9,0	13,0	20,0	66,0	90,0	25,0	29,0	30,0	10,0	14,0
	DN 100	3,5	4,5	7,0	14,0	35,0	44,0	11,0	14,0	16,0	7,0	8,0
50	DN 100	5,5	6,5	11,0	22,0	53,0	66,0	15,0	18,0	21,0	11,0	12,0
60	DN 100	8,0	9,0	15,0	30,0	65,0	75,0	22,0	26,0	26,0	12,0	13,0
	DN 130	5,0	7,0	8,0	15,0	34,0	38,0	12,0	14,0	14,0	6,0	8,0

* RKN – splitter with condensation vessel

8. Examples of flue gas exhaust and combustion air supply solutions

Pic. 7 Flue gas exhaust and combustion air supply via separate pipes through the wall

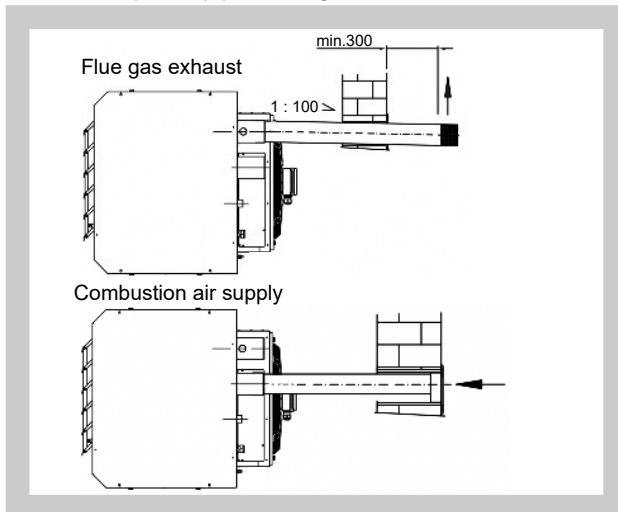

Pic. 8 Flue gas exhaust and combustion air supply via separate pipes over the roof

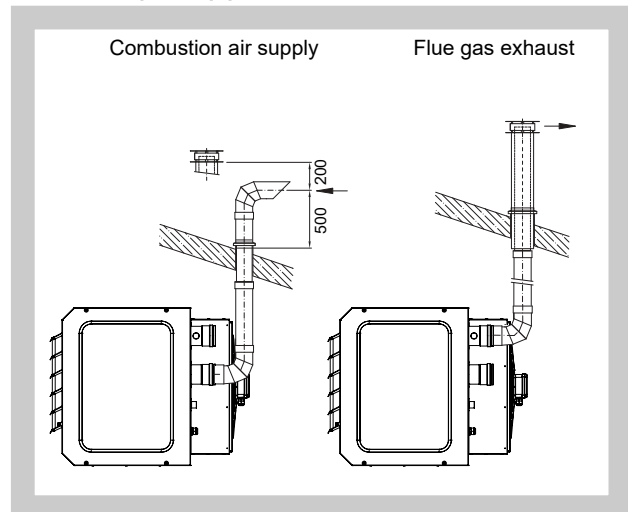

Pic. 9 Flue gas exhaust and combustion air supply via coaxial chimney through the wall

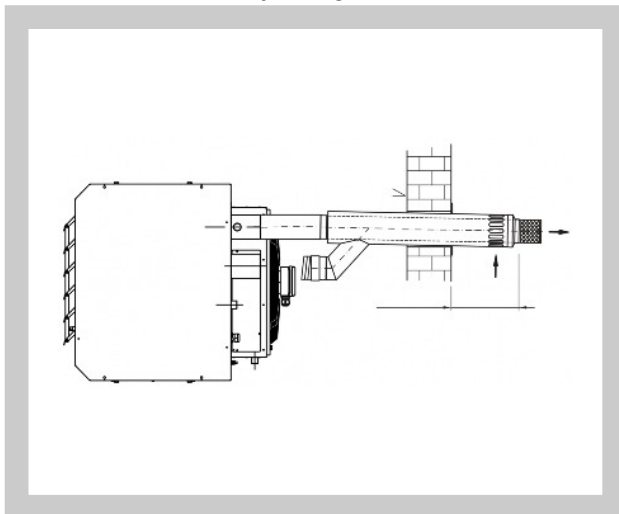

Pic. 10 Flue gas exhaust and combustion air supply via coaxial chimney over the roof

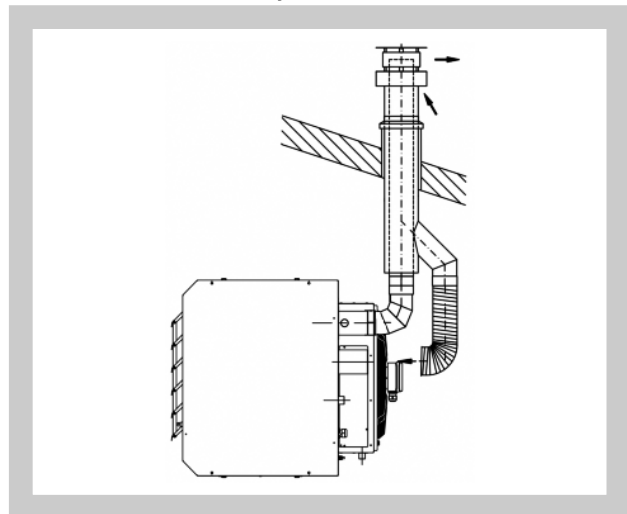

VI. INSTALLATION CONDITIONS

The heater must be installed in accordance with applicable standards and regulations.

Hot air heaters can not be installed in places with a potential explosion hazard such as storages of gasoline, solvents, oil, places with presence of chlorine vapor, trichlorethylene, perchlor, or high flammable dust and wood chips etc.

The equipment must be installed by qualified personnel, according to the manufacturer's instructions and applicable standards (EN 1020, Art. 7.4.; EN 15001-1, TPG 704 01)

BEFORE INSTALLING, CHECK:

- LOCAL CONDITIONS OF FUEL DISTRIBUTION, FUEL CHARACTERISTICS, OVERPRESSURE, EXISTING STATUS HEATER SETTINGS IN THE PRODUCTION PLATE ARE COMPATIBLE;
- MAIN CONDITIONS OF ELECTRICAL POWER SUPPLY ARE COMPATIBLE WITH ELECTRICAL DATA ON THE LABEL.

FUEL TEMPERATURE ON THE OUTPUT OF THE HEATER DOES NOT EXCEED 200 °C!

USE OF HEATERS IN CORROSIVE ENVIRONMENT IS PROHIBITED!

The minimum distance between the surface of the heater and the non-insulated flue gas pipe is 500 mm from all sides, except the front distance. Front distance is 3000 mm. It is not permitted to discharge flue gas through the wall / ceiling from combustible materials.

The manufacturer is not responsible for any damage caused by improper installation.

9. Installation principles

The conditions for connecting gas heaters to the for gas distribution and to the electricity network are given in chapters 10 a 11.

The design and installation of the flue gas duct must comply with the relevant standard. Examples of type installation are given in Chapter 8.

The amount of combustion air for heaters must comply with relevant standards and regulations.

Recommended installation height Z (mm) of heaters MONZUN-CP (with outlet with tilting louvers on discharge) is listed in Tab. 4.1.

Minimum space for heater installation:

Free access (min. 500 mm) to the burner chamber and to the exchanger must be provided from the sides. Determination of the safety distance of heaters and exhaust pipes from the surface of building materials must comply with the relevant standards.

Pic. 11 Connection points on the rear panel of the MONZUN-CP heater

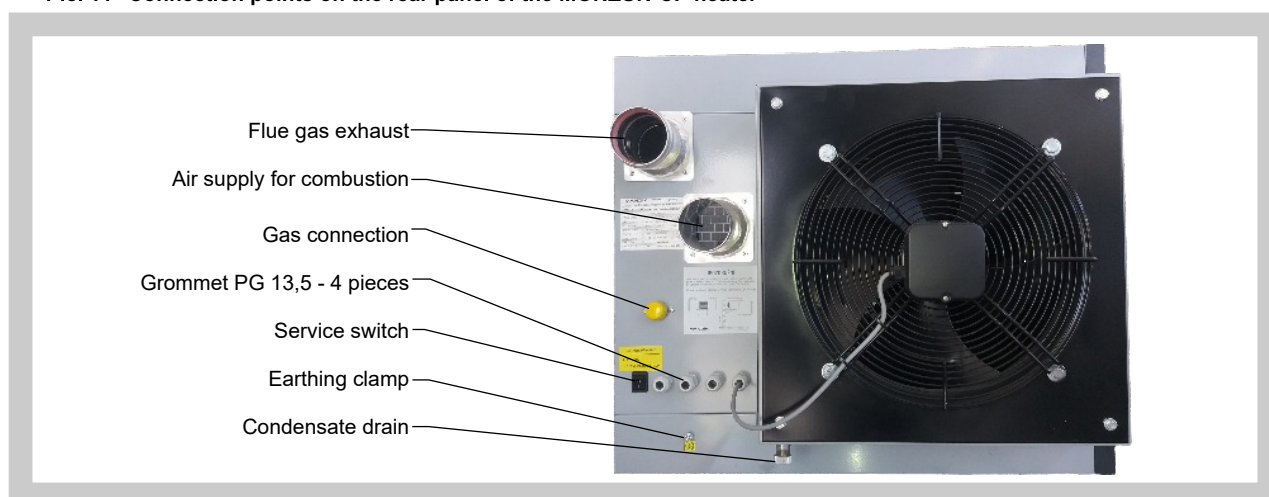

10. Gas connection installation

Connection of heaters with output power up to 50 kW is solved according to EN1775 Gas supply - gas pipelines in buildings - operational requirements; connection of heaters over 50 kW is solved according to EN 15001-1 Gas supply - Gas pipelines with operating pressure higher than 0.5 bar for industrial use and gas pipelines with operating pressure higher than 5 bar for industrial and non-industrial use. In the piping, a stable non-fluctuating gas pressure must be guaranteed during operation of the heater. See tab. 3.1.

The gas pipeline must be terminated with a gas ball valve near the heater connection (Pic. 12).

The actual connection of the heater to the gas through a flexible gas hose or through a screw connection. The gas inlet pipe is terminated with an external thread G3/4", the minimum gas hose diameter is 15 mm. The ball valve and gas hose are not part of the heater.

Pic. 12 Connection of the gas heater MONZUN-CP 15–60 to the gas distribution

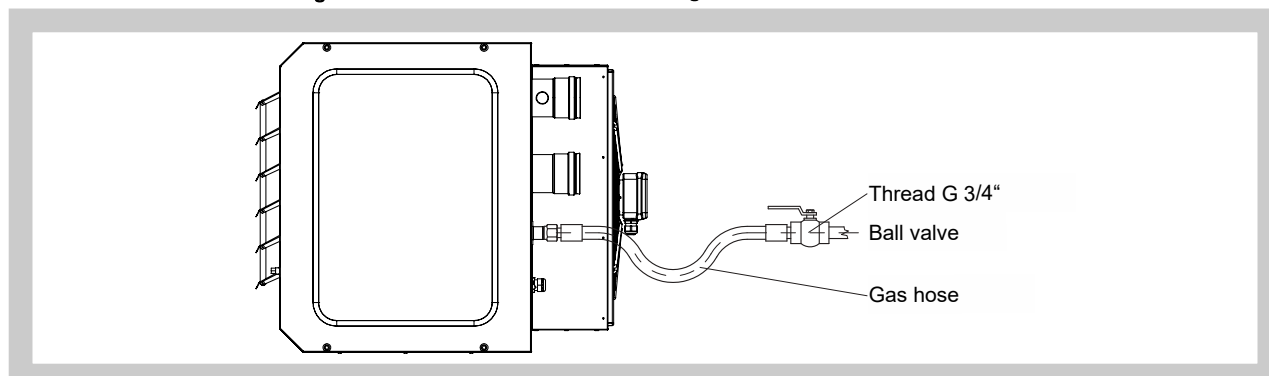

The heater must only be connected by an authorized organization. Before connecting, check that the type and pressure of the gas correspond to the data on the data label (on the rear panel of the heater). The gas hose is subject to regular inspections and inspections as gas distribution (TPG 704 01). Hoses must be protected against mechanical stress and aggressive substances. The hose must not be subjected to tension.

11. Electrical installation

The MONZUN-CP heaters are connected to the terminal block by a power supply with a stop switch / circuit breaker. The power input is decisive for supply sizing.

The MONZUN-CP heaters must be connected to the TN-S system in accordance with the applicable standards. The power supply must have the required protection according to the relevant standard.

According to EN 61140, MONZUN-CP heaters are class I electrical appliances and are equipped with a protective conductor connection terminal. This terminal must be connected acc. to the above standard.

Notice: After removal of the side door at the burner chamber, according to EN 60 947-1, the protection of the device is IP 00, is without protection (there is a risk of electric shock).

12. Condensate drain

Condensate, which forms in the heat exchanger of the MONZUN-CP heater, must be drained off.

The MONZUN-CP heater must be connected to a condensate drain. The condensate outlet is at the bottom of the fan carrier and has a G1 / 2 "external thread. The air heater contains a siphon in front of the condensate drain, therefore other siphon can not be included in the condensate drain! If the condensate drain is blocked, the unit will shut down.

If there is a risk of the heater freezing (eg when the heating is switched off for a long time), the siphon must be removed from the holder and the condensate poured out.

VII. OPERATION AND MAINTENANCE

- a) Gas hot-air heaters MONZUN-CP may only be used by a person instructed in using the device in a safe manner and who understands possible hazards.
- b) Persons with reduced physical or mental abilities or person that lack of experience and knowledge may only use the heater under the supervision of a person instructed under point (a).
- c) Children can not use or play with the gas hot-air heaters MONZUN-CP.

Tab. 7.1 Adjustment data for natural gas G20

Performance Series	15	20	30	40	50	60
Fan speed - nominal output power [min ⁻¹]	4000	5130	4800	6150	4800	5800
Starting fan speed	4000	4000	4000	4000	4100	4100
Fan speed - minimal output power [min ⁻¹]	1050	1050	1100	1100	1250	1250
Oxygen content in flue gas at rated output [%]	5,5	5,5	5,5	5,5	5,4	5,4

Tab. 7.2 Adjustment data for natural gas G25

Performance Series	15	20	30	40	50	60
Fan speed - nominal output power [min ⁻¹]	4000	5130	5000	5900	4500	5400
Starting fan speed	4000	4000	4000	4000	4100	4100
Fan speed - minimal output power [min ⁻¹]	1050	1050	1100	1100	1250	1250
Oxygen content in flue gas at rated output [%]	5,5	5,5	5,3	5,3	5,4	5,4



Tab. 7.3 Adjustment data for propane, propane-butane

Performance Series	15	20	30	40	50	60
Fan speed - nominal output power [min ⁻¹]	4100	5100	4900	5800	4600	5500
Starting fan speed	4000	4000	3500	3500	4500	4500
Fan speed - minimal output power [min ⁻¹]	1100	1100	1150	1150	1500	1500
Oxygen content in flue gas at rated output [%]	6,0	6,0	5,5	5,5	5,5	5,5



13. Commissioning

- a) Gas hot-air heaters MONZUN-CP may only be used by a person instructed in using the device in a safe manner and who understands possible hazards.
- b) Persons with reduced physical or mental abilities or person that lack of experience and knowledge may only use the heater under the supervision of a person instructed under point (a).
- c) Children can not use or play with the gas hot-air heaters MONZUN-CP.

Manual switch-on of heating:



With repeated pushing of left button select the heating mode  and the comfort mode . If the room temperature is lower than the set comfort one, the heater switches on. In case the set comfort temperature is below the current room one, increase it by turning the wheel clock-wise, the required temperature blinks and has no thermometer symbol. The heater burner output is modulated depending on the difference between the requested and current room temperature.

Manual switch-on of ventilation (summer operation):

With the left button set the cooling mode  and comfort . If the room temperature is below than the set comfort one, the heater fan switches on. Provided the current room temperature is below the set comfort one, you shall lower the requested comfort temperature below the current one in order to switch on the ventilation.

14. Decommissioning

Manual switch-off of heating:

Using the left button set the mode with a requested temperature below the current room temperature (attenuation, , antifreeze ) or turn the wheel anti-clockwise to reduce the requested comfort temperature. The heater burner switches off and stops to heat the exchanger. Following the exchanger cooling-down the heater fan gets switched off.

Manual switch-off of ventilation:

Use the left button to set another mode, for ex. cooling + anti-freezing or cooling + attenuation. The heater fan switches off immediately.

Notice:

- Shutdown in heating mode by main switch or shut off gas supply is prohibited. The only switch-off allowed is electric see. chapter "Shutdown".
- Only the electrical protection of the device, the main switch or the mains plug can be disconnected from the power supply. In this way, the device may only be switched off if it is not in the heating function and the air fan is not cooling the exchanger.

It is important to ensure that the air fan is not obstructed or that the shutters are closed, as this will change the operating conditions of the device (too high temperature of the exhaust air due to insufficient cooling of the exchanger) - risk of overheating of the device !!!

15. Maintenance

Regular annual inspections shall be carried out according to the relevant standard (is not part of warranty service). The manufacturer recommends to perform a professional service inspection once a year as described by the manufacturer, in particular:

- safety devices of the appliance;
- tightness of the exchanger, the exhaust system and its integrity;
- tightness of gas appliance installation.

In contaminated environments, dust that may accumulate on the blinds, air fan grille, and around the heat exchanger must be regularly removed..

All professional work may only be performed by a service technician with appropriate certification and authorization from the company MANDIK, a. s.

16. Failures and their elimination

Before solving a MONZUN-CP heater fault, we recommend:

Make sure the gas caps are open.

Check the power cables and control presets. Most commissioning failures result from poor cable installation, which can lead to damage to the controller.

- 230 V between phase L1 and neutral conductor N
- 230 V between phase L1 and a protective conductor PE
- 0 V neutral conductor N and a protective conductor PE

Make sure that the room thermostat is set to heating.

After each repair or rebuilding, the heater must be re-commissioned by a service technician authorized by MANDÍK, a. s.

Heater failure	Cause	Removal
The electric indicator light is off power (green light)	faulty light	replace the light
	Fuses (circuit breakers) dropped	replace fuses (switch circuit breaker)
	grid failure	remove the fault of the grid
The burner fan does not work	faulty burner fan	replace the burner fan
	defective automatic control	replace the control automatic
	faulty burner thermostat	replace the burner thermostat
	defective emergency thermostat	replace the emergency thermostat
	faulty thermal protection of the air fan	replace the air fan
	defect in wiring	check the electrical connection
	defective level relay	replace level relay
	high condensate level	release the condensate drain
Can't start - burner fan works	defective gas valve	replace the gas valve
	defective control automatic	replace control automatic
	electrodes or electrode cables not assembled or defective	replace or set correctly
	wrong electrode grounding	ground properly
	poorly set starting power	properly set start power
	low gas pressure in the distribution	increase the pressure in the distribution
The burner starts, but then goes off	defective ionisation electrode	replace ionisation electrode
	defective ionisation electrode cable	replace cable
	clogged flue gas exhaust or combustion air supply	check and clean the flue gas exhaust system and combustion air supply system
	defective or incorrectly set chimney manostat	Replace or adjust the manostat
The burner goes out and red overheating indicator lights up	overheated exchanger	unlock thermostat
	defective emergency thermostat	replace the emergency thermostat
The air fan is still starting and stopping	incorrectly set thermostat of the fan	set the fan thermostat
The air fan does not start	defective air fan	replace the air fan
	faulty capacitor of the fan	replace the capacitor
	defective fan thermostat	replace the fan thermostat

Notice:

When the burner is running, it is necessary to avoid shutting down the electric power supply! This can lead to overheating of the exchanger through thermal inertia - it does not cool down.

In case of overheating of the heater (failure of the air blower, thermostat of the burner, closed blinds, failure of the electric current during the operation of the burner...) and subsequent blocking of the emergency thermostat let the heater cool down, remove the fault and unlock the thermostat (unscrew the cover of the emergency thermostat and use a tool (rod, screwdriver, ...) Press the unlock button), in case of failure or repetition of the fault, contact the service organization or the manufacturer.

Under no circumstances should there be a blockage or clogging of the flue gas exhaust duct or combustion air intake.

VIII. INSTALLATION AND DISASSEMBLY OF COMPONENTS

ALL THESE OFFERED OPERATIONS MAY BE CARRIED OUT, THE FOR SERVICE PURPOSES, BY THE SERVICE ENGINEER ONLY WITH RELEVANT CERTIFICATE FROM MANDÍK, a.s.

Burner Assembly Removal:

1. Disconnect the MONZUN-CP heater from the electrical network and close the gas supply.
2. Remove the door of the burner box.
3. Disconnect the internal gas hose.
4. Disconnect the cable connectors from the burner fan.
5. Disassemble the burner assembly.
6. Install in reverse order and perform a leak test.

Electrode Removal (Adjustment):

1. Disconnect the MONZUN-CP heater from the electrical network and close the gas supply.
2. Remove the door of the burner box.
3. Disassemble the electrodes with cable located on the torch holder.
4. Install in reverse order and check that the electrodes are set correctly, adjust the distance between the electrodes. Check the function of the device.

Pic. 13 Electrode Adjustment

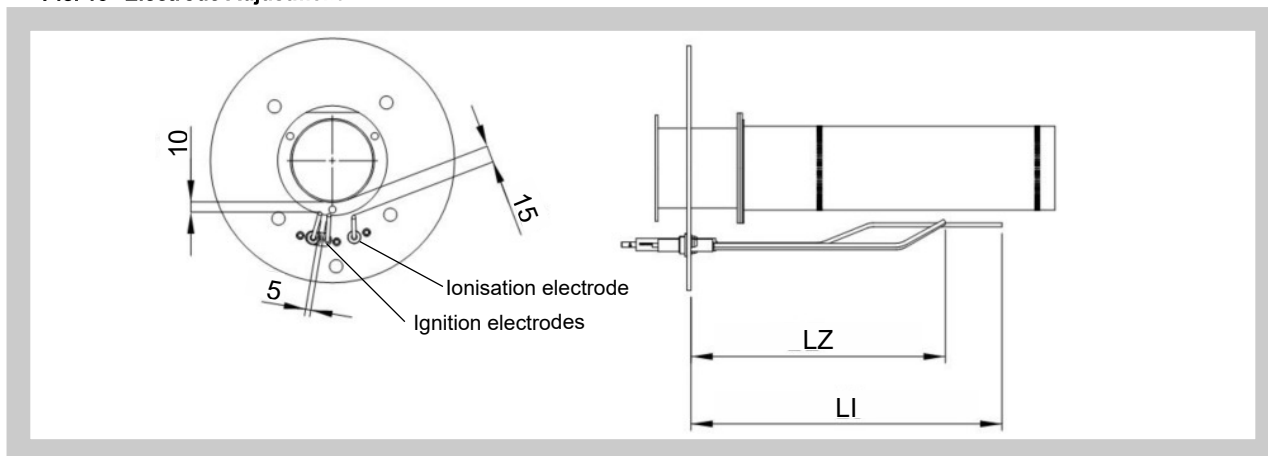

Tab. 8.1 Electrode lengths

Performance range MONZUN	Length of ignition electrode LZ (mm)	Length of ionization electrode LI (mm)
15, 20	130	130
30, 40	130	130
50, 60	130	130

Burner Fan Removal:

1. Disconnect the MONZUN-CP heater from the electrical network and close the gas supply.
2. Remove the door of the burner box.
3. Disconnect the cable connectors from the exhaust fan.
4. Disassemble the burner assembly.
5. Disassemble the burner fan.
6. Install in reverse order, replace fan seal.

Dismantling of the control automatic:

1. Disconnect the MONZUN-CP heater from the electrical network and close the gas supply.
2. Remove the door of the burner box.
3. Disconnect the cable connectors of the control automatic.
4. Disassemble the control unit.
5. Install in reverse order and check the function of the device.

Disassemble the gas valve and Venturi tube:

1. Disconnect the MONZUN-CP heater from the electrical network and close the gas supply.
2. Remove the door of the burner box.
3. Disconnect the internal gas hose.
4. Remove the control automatic from the gas valve.
5. Disassemble the Venturi with the gas valve (2 M6 screws with 4 mm hex).
6. Remove the gas valve from the Venturi tube (3 M6 screws with 4 mm hex).
7. Install in the reverse order and perform a leak test and check the function of the device.

Venturi tube adjustment at replacement:

This is a pre-setting of a mixture that is easy to ignite.

1. Install the Venturi tube to the gas valve and then together to the burner fan.
2. Completely close the richness adjusting screw = tighten as far as it will go, then loosen the number of turns according to the table 8.2.

ADJUSTING ACCORDING TO THE FLUE ANALYSER IS NECESSARY!

Tab. 8.2 Pre-setting the richness of the mixture after replacing the Venturi tube

Monzun	Fuel	Venturi tube	Number of turns of adjusting screw from fully closed = loosen the screw
15	G20 (natural gas)	203	6,5
	G25 (natural gas)		7,5
	G30/G31 (propane-butane)		3
20	G20 (natural gas)		6,5
	G25 (natural gas)		7,5
	G30/G31 (propane-butane)		3
30	G20 (natural gas)	202	5,5
	G25 (natural gas)		6,5
	G30/G31 (propane-butane)		2
40	G20 (natural gas)		5,5
	G25 (natural gas)		6,5
	G30/G31 (propane-butane)		2
50	G20 (natural gas)	201	5
	G25 (natural gas)		6
	G30/G31 (propane-butane)		1,5
60	G20 (natural gas)		5
	G25 (natural gas)		6
	G30/G31 (propane-butane)		1,5

Removing the Air Fan:

1. Disconnect the MONZUN-CP heater from the electrical network and close the gas supply.
2. Remove the door of the burner box.
3. Disconnect the air fan cable from the terminal box.
4. Remove the air fan from the fan carrier.
5. Install in reverse order and check the function of the device.

17. Conversion to another type of fuel

Conversion of the MONZUN-CP heaters to other fuels may only be carried out by a service technician authorized by MANDÍK, a.s. the heater is then put back into operation.

Equipment required:

- Flue gas analyser
- Computer with Honeywell ESYS software and cable for connection to the control automatics Honeywell, or a computer with the LabVision program and a converter for connection to the EBM Pabst control system.
- 4mm allen key for Honeywell, or 2mm allen key for EBM Pabst, for setting the richness of the mixture

When converting to a different fuel, no parts are replaced, the rebuilding consists in setting the appliance to a new fuel.

The setup has 2 steps:

1. Setting the burner fan speed to the respective fuel, see Tables 7.1 to 7.3. (page 11). The speed setting is performed from the computer using Honeywell ESYS software, for EBM Papst controllers using LabVision. The computer is connected with control automatics by Honeywell DI100001U cable, or a special converter for EBM Papst automatics. The heater must be connected to the power supply to set the speed.
2. The fuel / air richness is adjusted by the adjusting screw on the bottom of the Venturi tube. By loosening the screw, the fuel is added to the mixture, and the fuel goes away by tightening. The adjusting screw has a right-hand thread.

When adjusting the richness of the mixture, first perform a pre-adjustment on the heater switched off, and after switching on the heater and igniting the burner, adjust the richness of the mixture using the flue gas analyser to the values in Tables 7.1 to 7.3. (see page 11).

Tab. 8.3 Pre-setting the richness of the mixture for individual conversions

Original fuel	New fuel	Direction of rotation by adjusting screw	Number of turns of adjusting screw
G20	G25	+ loosen	1
G25	G20	- tighten	0
G20	G30/G31	- tighten	3,5
G30/G31	G20	+ loosen	5

The pre-setting is only to prepare a new fuel blend that can easily be ignited.

ADJUSTING ACCORDING TO THE FLUE ANALYSER IS NECESSARY!

After setting the richness of the mixture, check the heater function, especially the cold starts.

Pic. 14 Burner assembly, with Honeywell automatocs, combustion adjustment

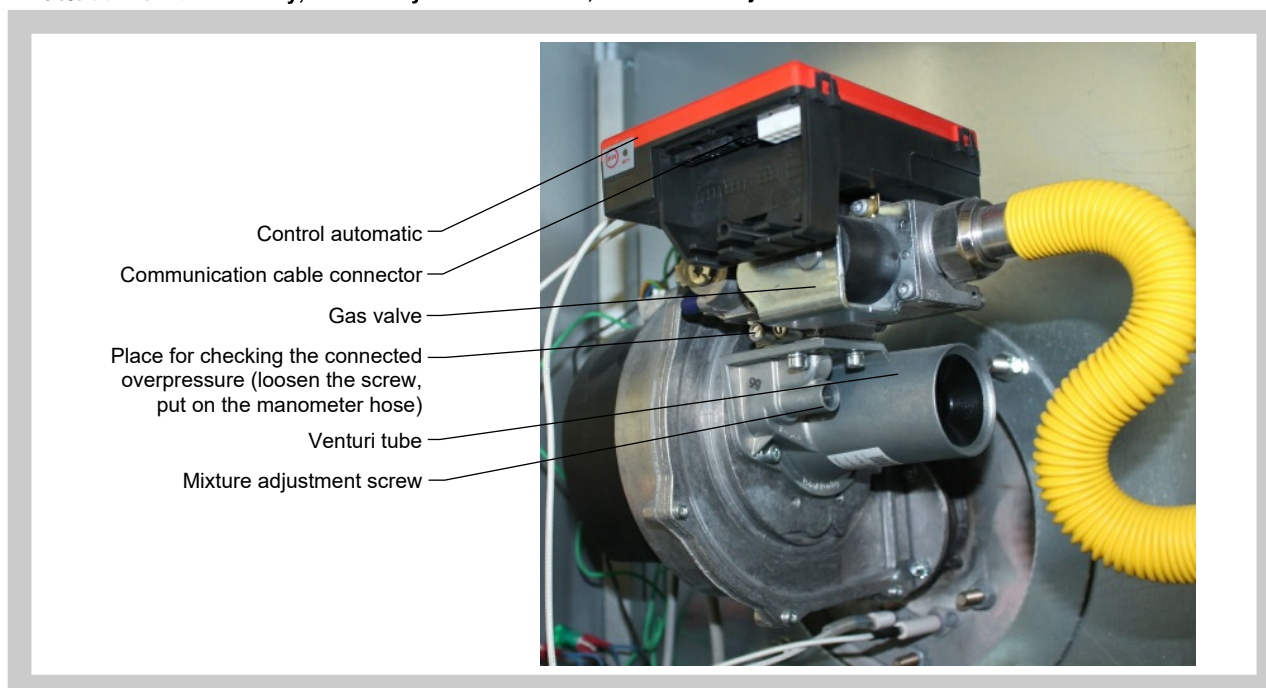

Pic. 15 Burner assembly, with EBM Pabst automatocs, combustion adjustment

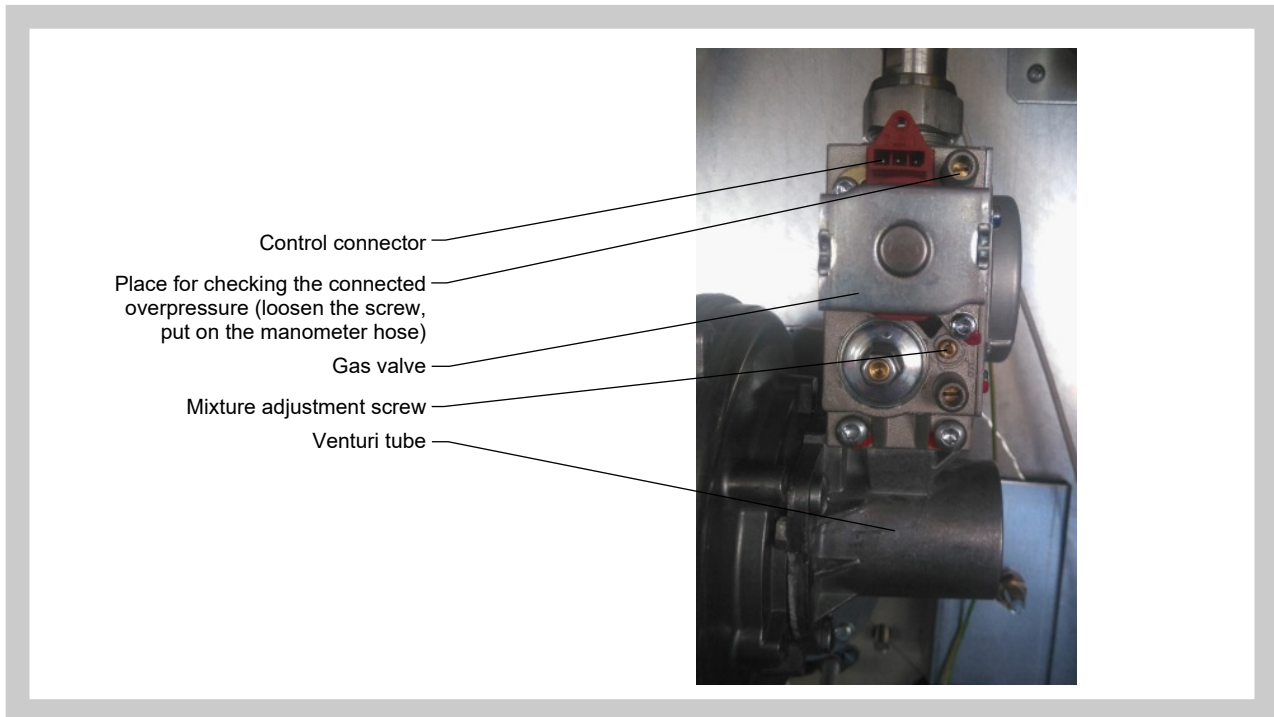

18. Components used in heaters MONZUN

Gas valve:

Honeywell VK4115V2012B
EBM Pabst G20E01 BC1CS

Control automatic:

Honeywell S4965V3166B
Honeywell S4965V3250
EBM Pabst 900MN

Burner fans:

EBM Papst

Venturi tube:

Honeywell, EBM Papst

Thermostats:

TG (REGULUS)
IMIT (COMTHERM)

Axial air fans:

EBM Papst
ZIEHL – ABEGG
AFL

Manostats:

SIT
DBL (industrietechnik)

19. Recycling and disassembly at end of service life

Once the service life is over, the old equipment can be disposed of in the following ways:

1. When purchasing a new device, the supplier will take back the old heater and ensure its disposal.
2. Hand over the old heater to the manufacturer for disposal.
3. Disassemble the heater and give it away as scrap.

It is necessary to disassemble at least these parts:

- Fans, Venturi tubes, gas valve and heater wiring are electrical waste
- The heater shell is a lightweight 27 grade steel waste
- The exchanger, burner and burner extension are alloyed steel waste, class 025

IX. CONTROL

20. Wiring diagram

Pic. 16 Electrical circuit diagram of MONZUN-CP heaters 15 to 40, with a Honeywell automatics

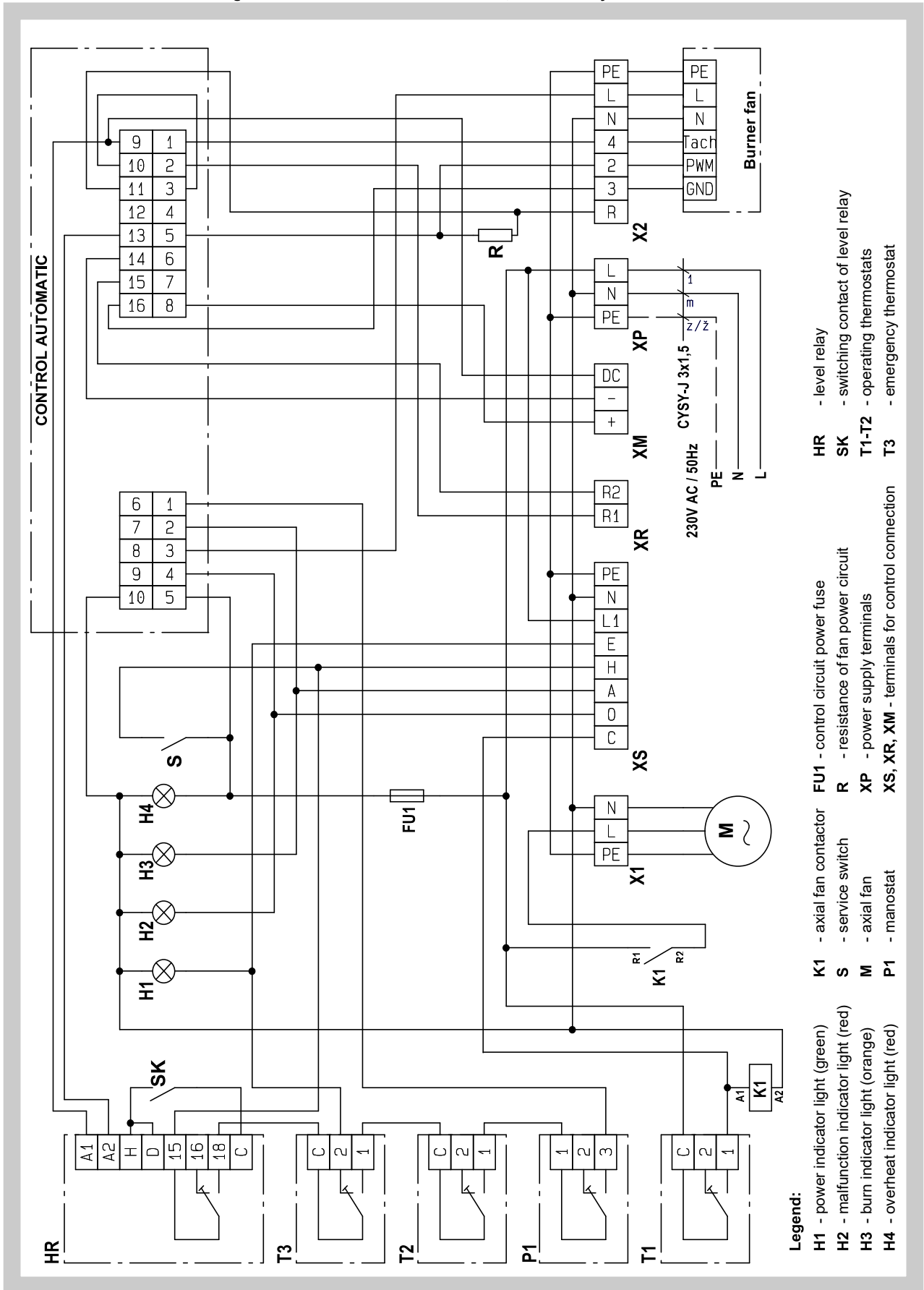

Pic. 17 Electrical circuit diagram of MONZUN-CP heaters 50 and 60, with a Honeywell automatics

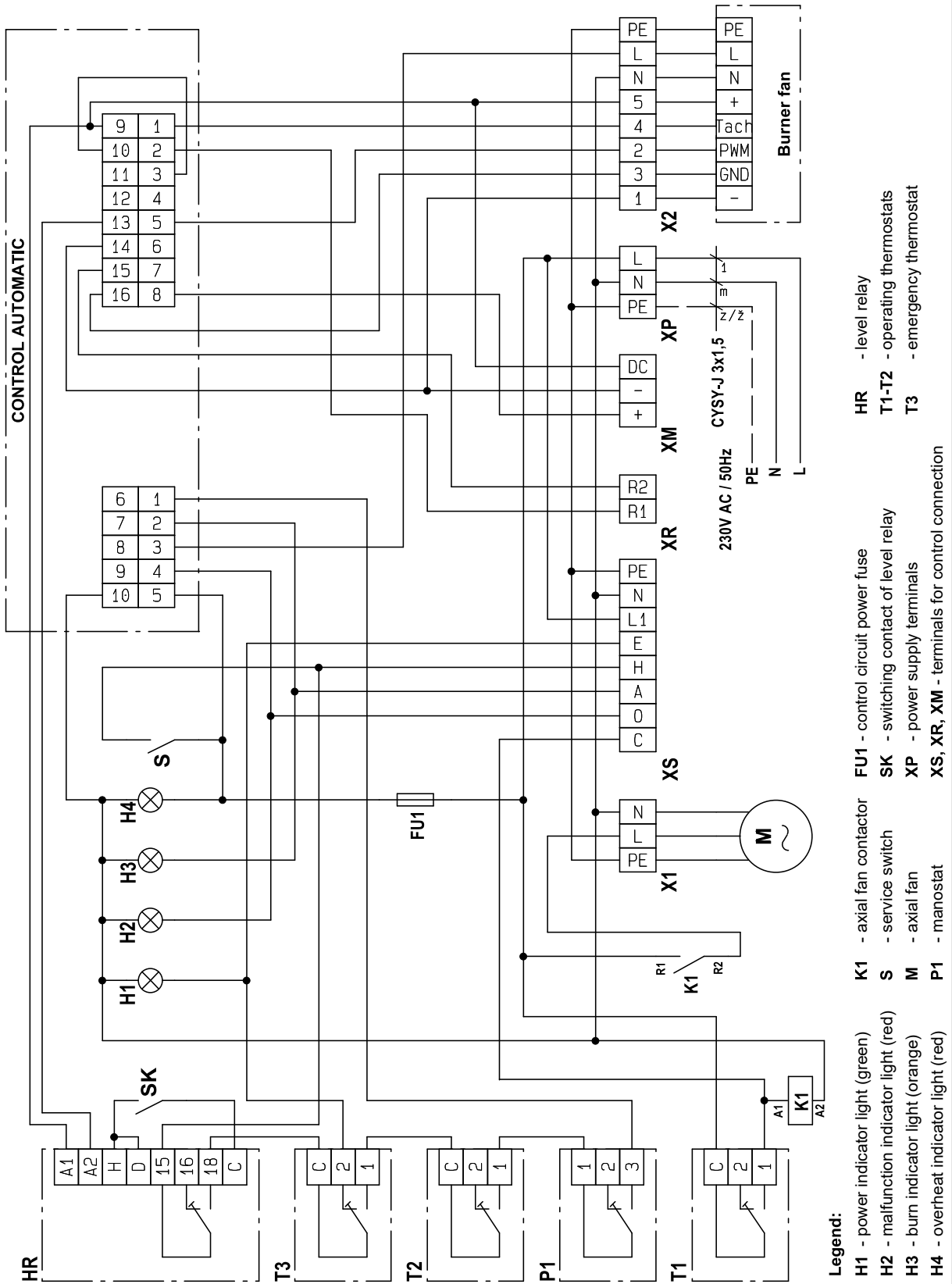

Pic. 18 Electrical circuit diagram of MONZUN-CP heaters 15 to 60, with a EBM Pabst automatics

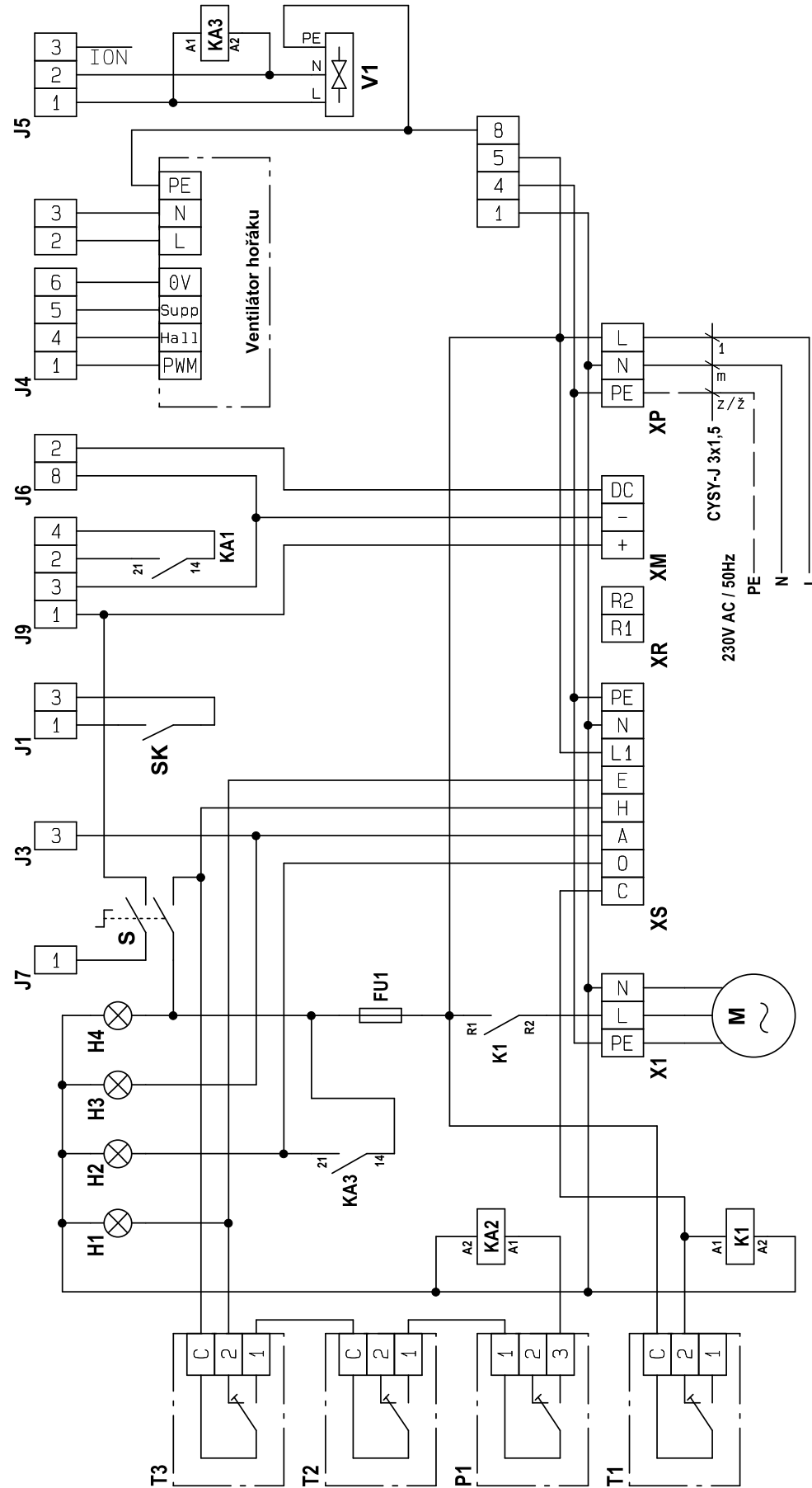

Legend:

- H1 - power indicator light (green)
- H2 - malfunction indicator light (red)
- H3 - burn indicator light (orange)
- H4 - overheat indicator light (red)
- S - service switch
- K1 - axial fan contactor
- KA2 - run enable switching relay
- KA3 - running signaling switching relay
- M - axial fan
- FU1 - control circuit power fuse
- V1 - gas valve
- XP - power supply terminals
- XS, XR, XM - terminals for control connection
- J - automation control connectors
- SK - switching contact for siphon monitoring
- T1-T2 - operating thermostats
- T3 - emergency thermostat

21. Control box

MMS control box is used to control gas air heaters MONZUN-CP.

It includes a room thermostat Siemens RDG160T that is used to control and modulate the heater, reset button and terminal board. The heater control can be manual or based on a week program. Heater performance modulation is automatic in both cases, depending on the requested and measured room temperature.

The control box belongs to optional accessories and if not connected, the heater starts with minimum output following switching-on by service switch.

Fig. 19 Connection diagram of the MONZUN-CP heater with control box MMS

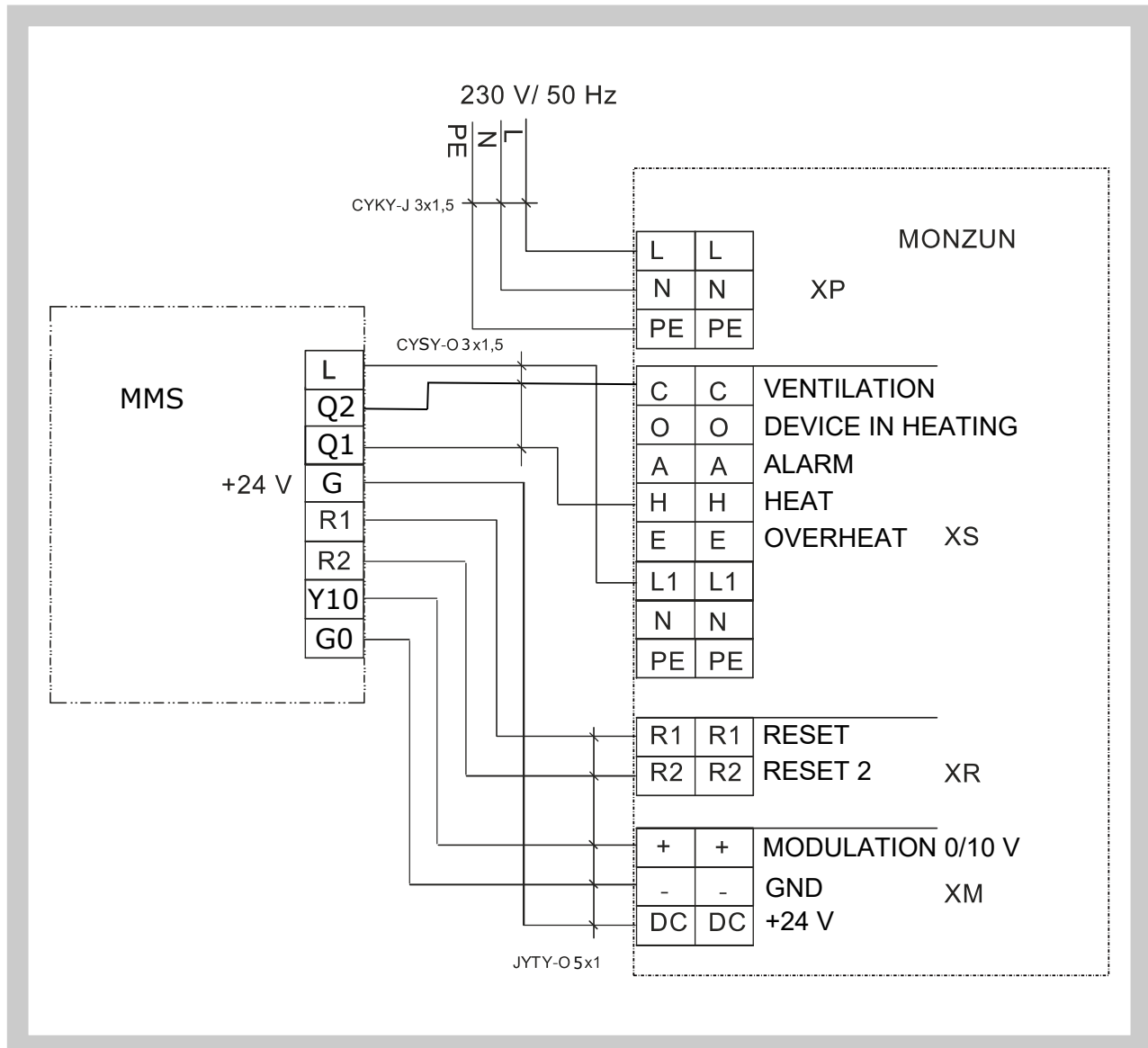

X. CHECKING AND TESTING

The device is preset by the manufacturer, its operation depends on correct installation and adjustment. All equipment is tested for safety and serviceability when finished.

XI. LOGISTIC DATA

MONZUN-CP heaters are packed in cardboard boxes on special pallets. The package allows you to store up to three heaters on top of each other.

They are transported with covered vehicles. During transport, heaters must be protected against mechanical damage and weathering. There must be no vibration and the ambient temperature must not exceed +50 °C.

The heaters must be stored in covered buildings, in an environment free from aggressive vapours, gases and dust. Temperatures in the range -5 to +40 °C and relative humidity max. 80% must be maintained in the buildings. During handling and storage, the heaters must be protected against mechanical damage.

XII. PRODUCT DATA

22. Data label

Pic. 20 Data label of MONZUN-CP heater

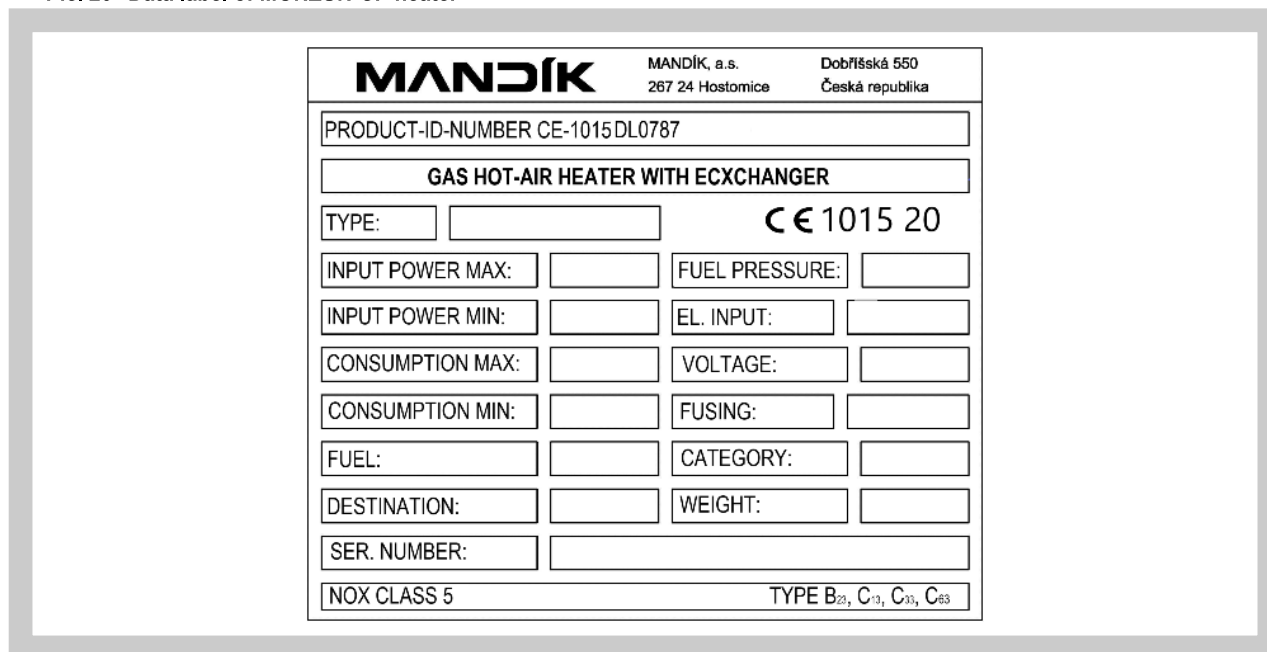

XIII. ORDERING DATA

23. Ordering key

MONZUN 20 Z - ZP

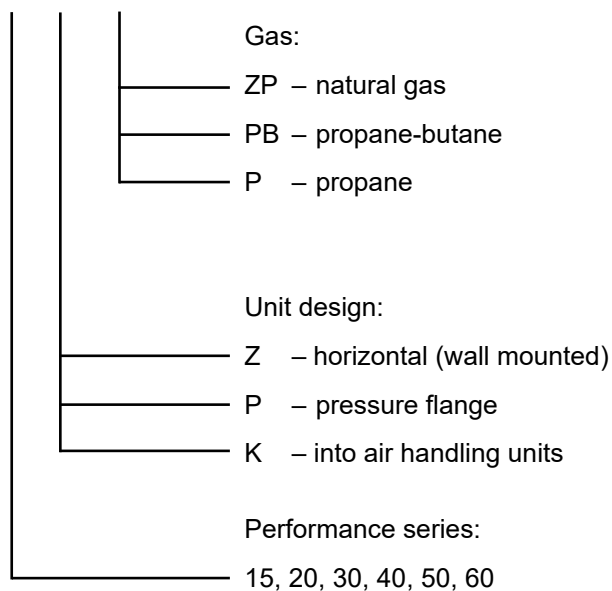

Ordering example:

MONZUN-CP 30 Z-ZP

Hot air gas heater Monzun, power series 30, wall mounted design, fuel natural gas

XIV. OPTIONAL ACCESSORIES

24. Mixing chamber

Mixing chamber is intended for mixing of outdoor and circulating air. It consists of a body made of galvanized sheet metal and three louvers flaps designed to adjust the selected air ratio in the range of 0 to 100%.

For outdoor air, the damper is tight, for circulation air two leaking dampers. The control dampers are mechanically coupled with manual (design .01) or continuous control actuator (design .57).

The mixing chamber is available with or without G2 filtration fabric.

Pic. 21 Mixing chamber, design without filter cloth, with manual control

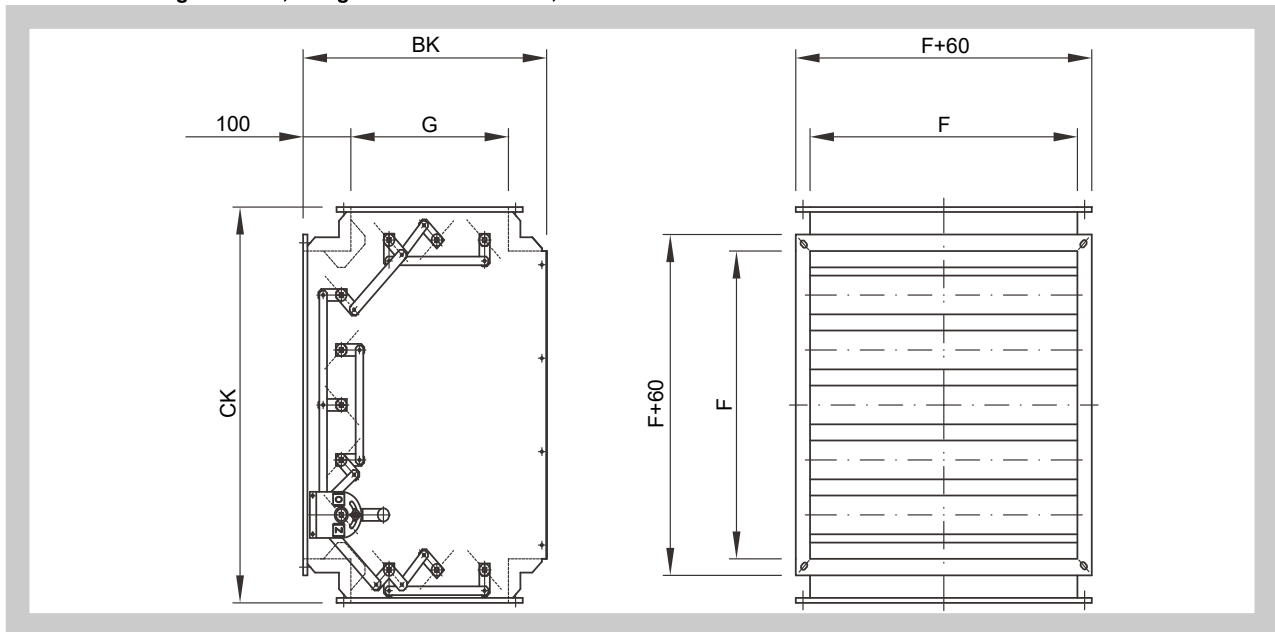

Tab. 14.1 Dimensions and weights of mixing chambers

MONZUN	Dimension [mm]				Weight [kg]
	F	BK	CK	G	
15, 20	500	480	660	300	24
30, 40	560	510	720	330	28
50, 60	710	585	870	405	40

Pic. 22 Connection diagram of the SGF24M control box and up to 2 Belimo SM24A-SR actuators

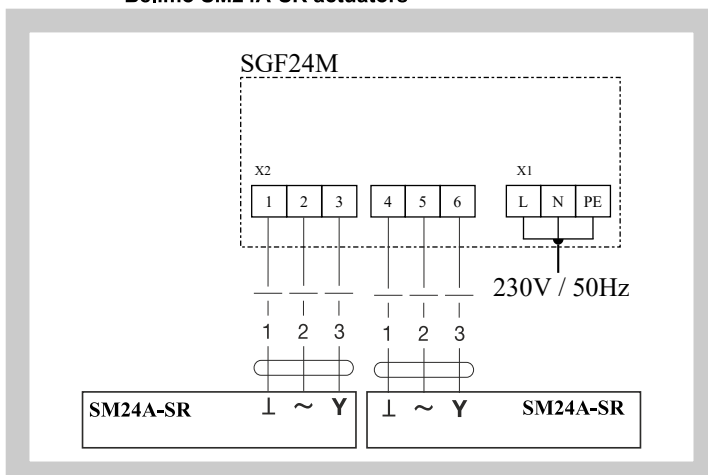

Tab. 14.2 Actuator Belimo SM 24A-SR

BELIMO actuator	SM 24A-SR
Power voltage	AC 24 V / 50 Hz
Power input – in operation position – in the rest position	2,5 W 1,5 W
Dimensioning	5 VA (Imax 8,3 A @ 5ms)
Control signal	DC 0... 10 V @ Ri 100kΩ
Adjustment time	150 s
Operating temperature	-30 °C ... +50 °C
Weight	1050 g

25. Fixed console

Fixed console is used to install MONZUN-CP heaters on a supporting vertical structure. One pair of fixed consoles is used for one heater.

Pic. 23 Fixed console

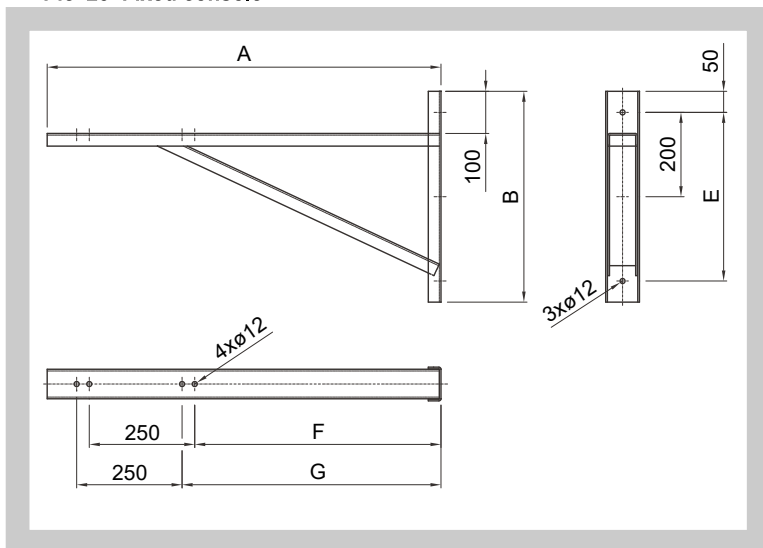

Tab. 14.3 Fixed console dimensions

Dimensions [mm]				
A	B	E	F	G
935	500	400	585	615

26. Swivel console

Swivel console for installation of MONZUN-CP heaters on a supporting vertical structure allowing the device to rotate on both sides. After installation, the swivel console must be firmly fixed. In this way, the heater is attached only to the hinge points located on the bottom panel.

Note: The heater must not be in collision with the flue gas outlet and the gas supply.

Pic. 24 Swivel console

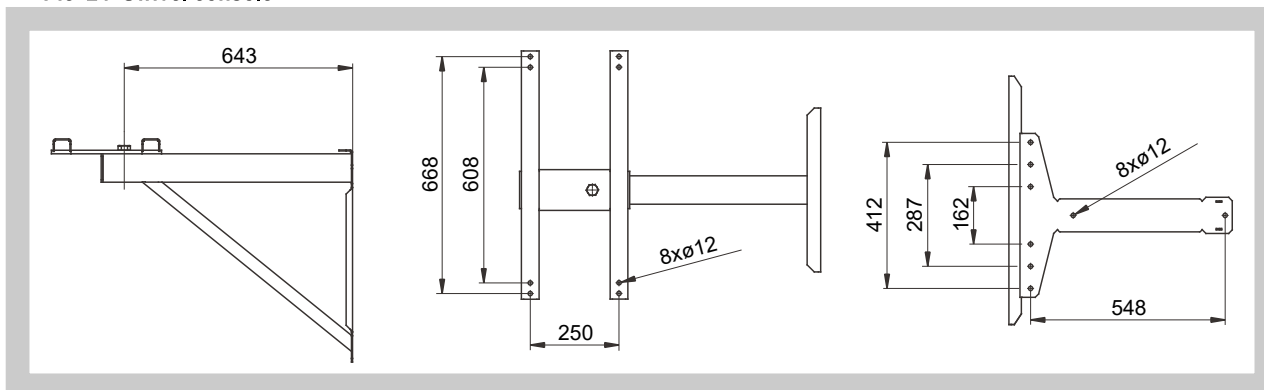

27. Roof section

The roof section is designed to be installed in the roof opening, serves to fasten the roof head. It consists of an oven with dimensions F x F and a length of 600 mm and four free rails, which are mounted according to the roof pitch on the pipe. Everything is made of galvanized sheet metal.

Pic. 25 Roof section

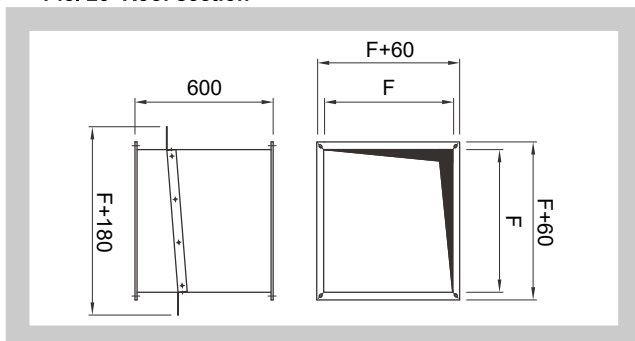

Tab. 14.4 Dimensions of roof section

MONZUN	Dimensions [mm]	Weight [kg]
15, 20	500	14
30, 40	560	16
50, 60	710	21

28. Roof warhead

The roof warhead is designed to be installed in the roof opening, serves to fasten the roof head. It consists of an oven with dimensions $F \times F$ and a length of 600 mm and four free rails, which are mounted according to the roof pitch on the pipe. Everything is made of galvanized sheet metal.

Pic. 26 Roof warhead

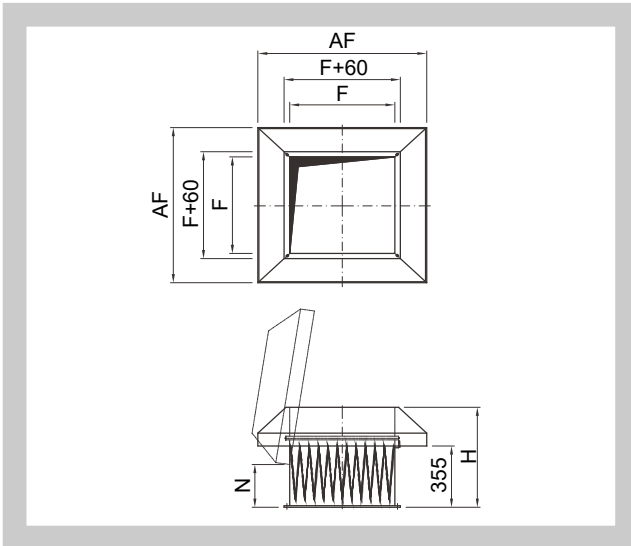

Tab. 14.5 Dimensions of roof warhead

Monzun	Dimension				Weight [kg]
	F	AF	H	N	
15, 20	500	840	590	252	24
30, 40	560	900	590	252	27
50, 60	710	1100	650	227	37

29. Passage part

The passage part is designed to be built into the hole in the vertical structure for the outdoor air intake. It is an oven with a free flange with dimension $F \times F$ and length 1000 mm (the length of the part is adjusted during assembly as needed). It is made of galvanized sheet metal.

Pic. 27 Passage part

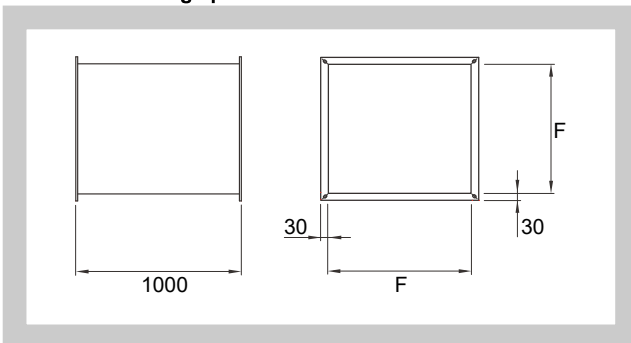

Tab. 14.6 Dimensions - Passage part

Monzun	Dimension F [mm]	Weight [kg]
15, 20	500	13
30, 40	560	14,5
50, 60	710	23

30. Rain protection louver PDZM

Rain protection louver PDZM blind is designed to terminate the passage part on the outside wall. Characteristic dimension $F \times F$. Made of galvanized sheet metal.

Pic. 28 Rain protection louver PDZM

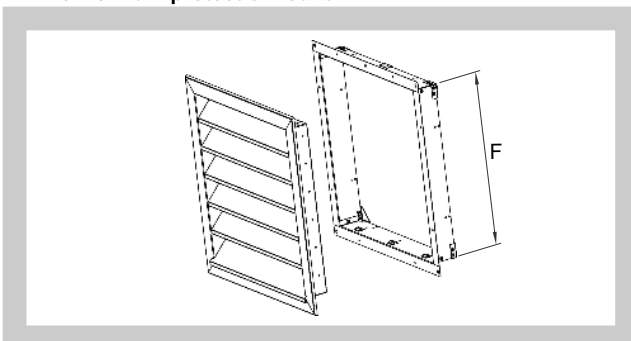

Tab. 14.7 Dimensions - Rain protection louver PDZM

Monzun	Dimension F [mm]	Weight [kg]
15, 20	500	4,5
30, 40	560	5,4
50, 60	710	7,8

XV. PRODUCT DATA ACCORDING TO COMMISSION REGULATION (EU) 2016/1188

Tab. 15.1 Fuel G20 - natural gas

Performance series	15	20	30	40	50	60
Nominal / maximal heating power output [kW]	15,5	19,4	29,3	36,5	46,8	55,0
Minimal heating power output [kW]	4,2	4,2	7,2	7,2	13,1	13,1
Electrical input power						
At nominal heating power output [kW]	0,139	0,145	0,340	0,350	0,411	0,440
At minimal heating power output [kW]	0,132	0,132	0,295	0,295	0,380	0,380
In standby mode [kW]	0,008	0,008	0,003	0,003	0,001	0,001
Useful efficiency at nominal heating power output (GCV) [%]	85,8	83,5	85,5	82,6	84,7	83,0
Useful efficiency at minimal heating power output (GCV) [%]	96,9	96,9	97,1	97,1	96,4	96,4
Nitrogen oxides emissions NOx mg/kWh (GCV)	58	53	39	62	45	45
Emission efficiency [%]	97,6	97,2	97,9	97,6	96,7	96,5
Heating season energetic efficiency [%]	92,4	91,8	92,3	92,3	91,5	90,9

Tab. 15.2 Fuel G25 - natural gas

Performance series	15	20	30	40	50	60
Nominal / maximal heating power output [kW]	15,4	19,4	29,2	35,0	46,1	54,7
Minimal heating power output [kW]	4,25	4,25	7,05	7,05	13,3	13,3
Electrical input power						
At nominal heating power output [kW]	0,139	0,145	0,340	0,350	0,411	0,440
At minimal heating power output [kW]	0,132	0,132	0,295	0,295	0,380	0,380
In standby mode [kW]	0,008	0,008	0,003	0,003	0,001	0,001
Useful efficiency at nominal heating power output (GCV) [%]	85,1	83,0	84,8	82,2	84,2	82,4
Useful efficiency at minimal heating power output (GCV) [%]	96,1	96,1	96,4	96,4	95,5	95,5
Nitrogen oxides emissions NOx mg/kWh (GCV)	58	53	45	45	45	45
Emission efficiency [%]	97,6	97,2	97,5	97,3	97,1	96,8
Heating season energetic efficiency [%]	92,0	91,9	92,5	92,3	91,0	90,8

Tab. 15.3 Fuel G30 - butane

Performance series	15	20	30	40	50	60
Nominal / maximal heating power output [kW]	15,2	19,3	29,1	35,2	46,7	54,8
Minimal heating power output [kW]	4,4	4,4	7,4	7,4	13,3	13,6
Electrical input power						
At nominal heating power output [kW]	0,140	0,145	0,340	0,350	0,411	0,440
At minimal heating power output [kW]	0,132	0,132	0,295	0,295	0,380	0,380
In standby mode [kW]	0,008	0,008	0,003	0,003	0,001	0,001
Useful efficiency at nominal heating power output (GCV) [%]	85,8	84,9	86,7	84,6	85,6	84,0
Useful efficiency at minimal heating power output (GCV) [%]	95,1	95,1	96,8	96,8	95,7	95,3
Nitrogen oxides emissions NOx mg/kWh (GCV)	60	60	60	60	60	60
Emission efficiency [%]	97,6	97,3	97,5	97,2	97,1	96,8
Heating season energetic efficiency [%]	91,0	90,7	92,6	92,1	90,9	90,5

Tab. 15.4 Fuel G31 - propane

Performance series	15	20	30	40	50	60
Nominal / maximal heating power output [kW]	15,2	19,3	28,8	36,3	47,7	54,9
Minimal heating power output [kW]	4,2	4,2	7,7	7,7	13,3	13,3
Electrical input power						
At nominal heating power output [kW]	0,140	0,145	0,340	0,350	0,411	0,440
At minimal heating power output [kW]	0,132	0,132	0,295	0,295	0,380	0,380
In standby mode [kW]	0,008	0,008	0,003	0,003	0,001	0,001
Useful efficiency at nominal heating power output (GCV) [%]	85,6	84,5	85,6	83,9	85,6	84,0
Useful efficiency at minimal heating power output (GCV) [%]	95,7	95,7	96,6	96,6	95,7	95,7
Nitrogen oxides emissions NOx mg/kWh (GCV)	60	60	60	60	60	60
Emission efficiency [%]	97,7	97,3	97,6	97,2	97,1	96,9
Heating season energetic efficiency [%]	91,7	91,2	92,4	91,9	90,9	90,6